

SRP-6MB(-HV) SERIES 6 INCH 60 CELLS

300-315w



KEY FEATURES



Bankable products



Top rank in Photon yield measurement



Safety for salt mist corrosion
Safety for ammonia corrosion



Safety for fire risk
(Class C tested in TÜV SÜD and Rheinland)



Outstanding power output capability at low irradiance



Triple 100% Electroluminescence (EL) tests minimize breakage rate



World 1st company to pass "Thresher Test" and "On-site Power Measurement Validation" certificate



Anti-PID products, passing TÜV SÜD system voltage durability test



Tested and certified according to newest IEC standard
IEC61730-1:2016 IEC61215-1:2016
IEC61730-2:2016 IEC61215-2:2016

MANAGEMENT SYSTEM

ISO 9001: Quality management system

ISO 14001: Standard for environmental management system

OHSAS 18001: International standard for occupational health and safety assessment system

INSURANCE

PICC

PRODUCT CERTIFICATES



WARRANTY

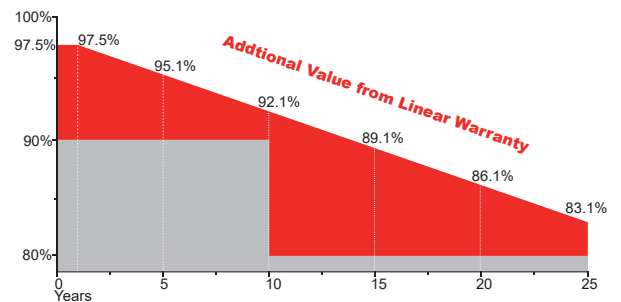

15 YEARS

Guarantee on product material and workmanship

25 YEARS

linear power output warranty

Specifications are subject to change without further notification SRP-DS-EN-2019V3.0 © Copyright 2019 Seraphim



SRP-XXX-6MB: Maximum System Voltage 1000 VDC.
 SRP-XXX-6MB-HV: Maximum System Voltage 1500 VDC.

SRP-6MB(-HV) SERIES 6 INCH 60 CELLS

Electrical Characteristics

Module Type	SRP-300-6MB SRP-300-6MB-HV		SRP-305-6MB SRP-305-6MB-HV		SRP-310-6MB SRP-310-6MB-HV		SRP-315-6MB SRP-315-6MB-HV	
	STC	NOCT	STC	NOCT	STC	NOCT	STC	NOCT
Maximum Power -P _{mp} (W)	300	223	305	226	310	230	315	234
Open Circuit Voltage -V _{oc} (V)	39.7	36.7	39.9	36.8	40.2	37.1	40.4	37.3
Short Circuit Current -I _{sc} (A)	9.65	7.82	9.76	7.91	9.82	7.96	9.92	8.05
Maximum Power Voltage -V _{mp} (V)	32.1	30.3	32.3	30.4	32.6	30.7	32.8	30.9
Maximum Power Current -I _{mp} (A)	9.35	7.36	9.45	7.44	9.51	7.50	9.61	7.58
Module Efficiency STC-η _m (%)	18.44/18.33		18.75/18.63		19.05/18.94		19.36/19.24	
Power Tolerance (W)	(0,+4.99)							
Maximum System Voltage (V)	1000VDC / 1500VDC							
Maximum Series Fuse Rating (A)	20A							
Pmax Temperature Coefficient	-0.36 %/°C							
Voc Temperature Coefficient	-0.28 %/°C							
Isc Temperature Coefficient	+0.05 %/°C							
Operating Temperature	-40~+85 °C							
Nominal Operating Cell Temperature	45±2 °C							

STC: Irradiance 1000 W/m² module temperature 25°C AM=1.5
 NOCT: Irradiance 800 W/m² ambient temperature 20°C wind speed :1m/s Power measurement tolerance: +/-3%

I-V Curve

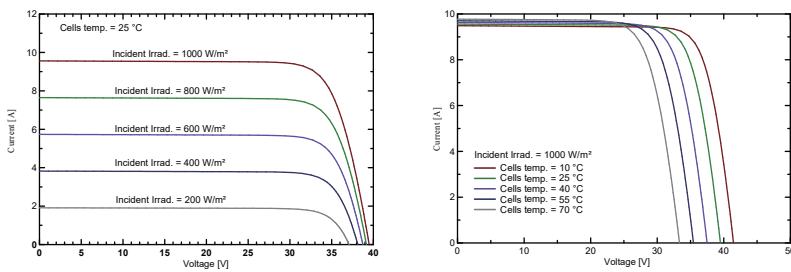

Technical drawing(SRP-XXX-6MB)

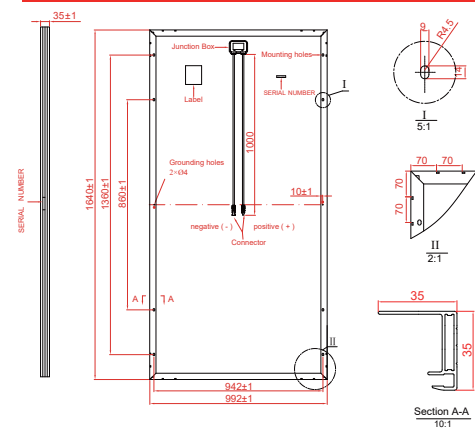

Mechanical Specifications

External Dimension	1640 x 992 x 35mm/1650 x 992 x 35mm
Weight	17.5kg/18.0kg
Solar Cells	PERC Mono crystalline 156.75 x 156.75 mm (60pcs)
Front Glass	3.2 mm AR coating tempered glass, low iron
Frame	Anodized aluminium alloy
Junction Box	IP68, 3 diodes
Output Cables	4.0 mm ² , cable length:1000 mm
Connector	MC4 Compatible
Mechanical Load	5400 Pa

Technical drawing(SRP-XXX-6MB-HV)

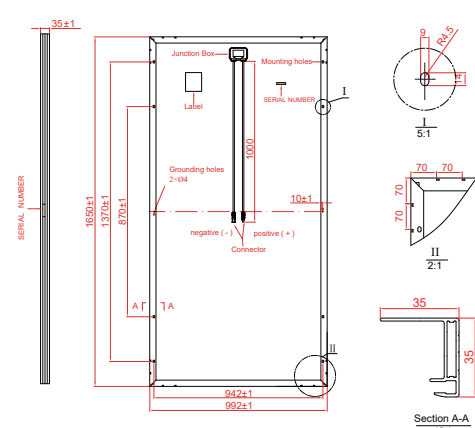

Packing Configuration

External Dimension	1640 x 992 x 35mm/1650 x 992 x 35mm		
Container	20'GP	40'GP	40'HQ
Pieces per Pallet	30	30	30+2*
Pallets per Container	12	28	28
Pieces per Container	360	840	896

* 30+2 pieces per pallet is the special package which only suits for container transport.For details,please consult SERAPHIM.

* All Dimensions in mm.
 * The above drawing is a graphical representation of the product.
 For engineering quality drawings please contact SERAPHIM.

Specifications are subject to change without further notification SRP-DS-EN-2019V3.0 © Copyright 2019 Seraphim

