

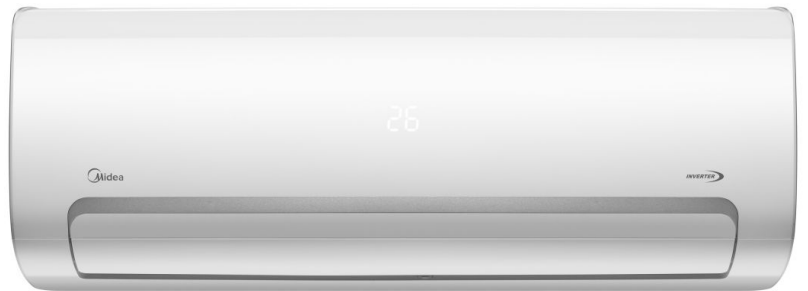

# MissionII 3D Inverter Series

Service Manual 2017



# CONTENTS

<b>1. Precaution</b> .....	<b>1</b>
1.1 Safety Precaution.....	1
1.2 Warning .....	1
<b>2 Information servicing</b> .....	<b>4</b>
<b>3. Model List</b> .....	<b>8</b>
<b>4. Dimension</b> .....	<b>9</b>
4.1 Indoor Unit.....	9
4.2 Outdoor Unit.....	12
<b>5. Refrigerant Cycle Diagram</b> .....	<b>15</b>
<b>6 Installation Details</b> .....	<b>16</b>
6.1 Wrench torque sheet for installation .....	16
6.2 Connecting the cables .....	16
6.3 Pipe length and the elevation .....	17
6.4 Installation for the first time .....	18
6.5 Adding the refrigerant after running the system for many years .....	19
6.6 Re-installation while the indoor unit need to be repaired .....	19
6.7 Re-installation while the outdoor unit need to be repaired .....	20
<b>7. Operation Characteristics</b> .....	<b>22</b>
<b>8. Wiring Diagram</b> .....	<b>23</b>
8.1 Indoor Unit.....	23
8.2 Outdoor Unit.....	24
<b>9. Electronic function</b> .....	<b>25</b>
9.1 Abbreviation .....	25
9.2 Display function.....	25
9.3 Main Protection .....	26
9.4 Operation Modes and Functions.....	27
<b>10. Troubleshooting</b> .....	<b>34</b>
10.1 Indoor Unit Error Display.....	35
10.2 Trouble shooting .....	36



**Caution: Risk of fire/flammable material**

# 1. Precaution

## 1.1 Safety Precaution

- To prevent injury to the user or other people and property damage, the following instructions must be followed.

- Incorrect operation due to ignoring instruction will cause harm or damage.

- Before service the unit, be sure to read this service manual at first.

## 1.2 Warning

### ➤ Installation

- Do not use a defective or underrated circuit breaker. Use this appliance on a dedicated circuit.

There is risk of fire or electric shock.

- For electrical work, contact the dealer, seller, a qualified electrician, or an authorized service center.

Do not disassemble or repair the product, there is risk of fire or electric shock.

- Always ground the product.

There is risk of fire or electric shock.

- Install the panel and the cover of control box securely.

There is risk of fire of electric shock.

- Always install a dedicated circuit and breaker.

Improper wiring or installation may cause fire or electric shock.

- Use the correctly rated breaker of fuse.

There is risk of fire or electric shock.

- Do not modify or extend the power cable.

There is risk of fire or electric shock.

- Do not install, remove, or reinstall the unit by yourself (customer).

There is risk of fire, electric shock, explosion, or injury.

- Be caution when unpacking and

installing the product.

Sharp edges could cause injury, be especially careful of the case edges and the fins on the condenser and evaporator.

- For installation, always contact the dealer or an authorized service center.

- Do not install the product on a defective installation stand.

- Be sure the installation area does not deteriorate with age.

If the base collapses, the air conditioner could fall with it, causing property damage, product failure, and personal injury.

- Do not let the air conditioner run for a long time when the humidity is very high and a door or a window is left open.

- Take care to ensure that power cable could not be pulled out or damaged during operation.

There is risk of fire or electric shock.

- Do not place anything on the power cable.

There is risk of fire or electric shock.

- Do not plug or unplug the power supply plug during operation.

There is risk of fire or electric shock.

- Do not touch (operation) the product with wet hands.

- Do not place a heater or other appliance near the power cable.

There is risk of fire and electric shock.

- Do not allow water to run into electrical parts.

It may cause fire, failure of the product, or electric shock.

- Do not store or use flammable gas or combustible near the product.

There is risk of fire or failure of product.

- Do not use the product in a tightly closed space for a long time.

Oxygen deficiency could occur.

- When flammable gas leaks, turn off the gas and open a window for ventilation before turn the product on.

- If strange sounds or smoke comes

**from product, turn the breaker off or disconnect the power supply cable.**

There is risk of electric shock or fire.

■ **Stop operation and close the window in storm or hurricane. If possible, remove the product from the window before the hurricane arrives.**

There is risk of property damage, failure of product, or electric shock.

■ **Do not open the inlet grill of the product during operation. (Do not touch the electrostatic filter, if the unit is so equipped.)**

There is risk of physical injury, electric shock, or product failure.

■ **When the product is soaked, contact an authorized service center.**

There is risk of fire or electric shock.

■ **Be caution that water could not enter the product.**

There is risk of fire, electric shock, or product damage.

■ **Ventilate the product from time to time when operating it together with a stove etc.**

There is risk of fire or electric shock.

■ **Turn the main power off when cleaning or maintaining the product.**

There is risk of electric shock.

■ **When the product is not be used for a long time, disconnect the power supply plug or turn off the breaker.**

There is risk of product damage or failure, or unintended operation.

■ **Take care to ensure that nobody could step on or fall onto the outdoor unit.**

This could result in personal injury and product damage.

### ➤ **CAUTION**

■ **Always check for gas (refrigerant) leakage after installation or repair of product.**

Low refrigerant levels may cause failure of product.

■ **Install the drain hose to ensure that**

**water is drained away properly.**

A bad connection may cause water leakage.

■ **Keep level even when installing the product.**

It can avoid vibration of water leakage.

■ **Do not install the product where the noise or hot air from the outdoor unit could damage the neighborhoods.**

It may cause a problem for your neighbors.

■ **Use two or more people to lift and transport the product.**

■ **Do not install the product where it will be exposed to sea wind (salt spray) directly.**

It may cause corrosion on the product.

Corrosion, particularly on the condenser and evaporator fins, could cause product malfunction or inefficient operation.

### ➤ **Operational**

■ **Do not expose the skin directly to cool air for long time. (Do not sit in the draft).**

■ **Do not use the product for special purposes, such as preserving foods, works of art etc. It is a consumer air conditioner, not a precision refrigerant system.**

There is risk of damage or loss of property.

■ **Do not block the inlet or outlet of air flow.**

■ **Use a soft cloth to clean. Do not use harsh detergents, solvents, etc.**

There is risk of fire, electric shock, or damage to the plastic parts of the product.

■ **Do not touch the metal parts of the product when removing the air filter. They are very sharp.**

■ **Do not step on or put anything on the product. (outdoor units)**

■ **Always insert the filter securely. Clean the filter every two weeks or more often if necessary.**

A dirty filter reduces the efficiency of the air conditioner and could cause product malfunction or damage.

■ **Do not insert hands or other objects**

through air inlet or outlet while the product is operated.

- **Do not drink the water drained from the product.**

- **Use a firm stool or ladder when cleaning or maintaining the product.**

Be careful and avoid personal injury.

- **Replace the all batteries in the remote control with new ones of the same type. Do not mix old and new batteries or different types of batteries.**

There is risk of fire or explosion.

- **Do not recharge or disassemble the batteries. Do not dispose of batteries in a fire.**

They may burn or explode.

- **If the liquid from the batteries gets onto your skin or clothes, wash it well with clean water. Do not use the remote if the batteries have leaked.**

## 2 Information servicing

### 1. Checks to the area

Prior to beginning work on systems containing flammable refrigerants, safety checks are necessary to ensure that the risk of ignition is minimised. For repair to the refrigerating system, the following precautions shall be complied with prior to conducting work on the system.

### 2. Work procedure

Work shall be undertaken under a controlled procedure so as to minimise the risk of a flammable gas or vapour being present while the work is being performed.

### 3. General work area

All maintenance staff and others working in the local area shall be instructed on the nature of work being carried out. Work in confined spaces shall be avoided. The area around the work space shall be sectioned off. Ensure that the conditions within the area have been made safe by control of flammable material.

### 4. Checking for presence of refrigerant

The area shall be checked with an appropriate refrigerant detector prior to and during work, to ensure the technician is aware of potentially flammable atmospheres. Ensure that the leak detection equipment being used is suitable for use with flammable refrigerants, i.e. no sparking, adequately sealed or intrinsically safe.

### 5. Presence of fire extinguisher

If any hot work is to be conducted on the refrigeration equipment or any associated parts, appropriate fire extinguishing equipment shall be available to hand. Have a dry powder or CO<sub>2</sub> fire extinguisher adjacent to the charging area.

### 6. No ignition sources

No person carrying out work in relation to a refrigeration system which involves exposing any pipe work that contains or has contained flammable refrigerant shall use any sources of ignition in such a manner that it may lead to the

risk of fire or explosion. All possible ignition sources, including cigarette smoking, should be kept sufficiently far away from the site of installation, repairing, removing and disposal, during which flammable refrigerant can possibly be released to the surrounding space. Prior to work taking place, the area around the equipment is to be surveyed to make sure that there are no flammable hazards or ignition risks. NO SMOKING signs shall be displayed.

### 7. Ventilated area

Ensure that the area is in the open or that it is adequately ventilated before breaking into the system or conducting any hot work. A degree of ventilation shall continue during the period that the work is carried out. The ventilation should safely disperse any released refrigerant and preferably expel it externally into the atmosphere.

### 8. Checks to the refrigeration equipment

Where electrical components are being changed, they shall be fit for the purpose and to the correct specification. At all times the manufacturer's maintenance and service guidelines shall be followed. If in doubt consult the manufacturer's technical department for assistance. The following checks shall be applied to installations using flammable refrigerants:

- the charge size is in accordance with the room size within which the refrigerant containing parts are installed;
- the ventilation machinery and outlets are operating adequately and are not obstructed;
- if an indirect refrigerating circuit is being used, the secondary circuit shall be checked for the presence of refrigerant; marking to the equipment continues to be visible and legible.
- markings and signs that are illegible shall be corrected;
- refrigeration pipe or components are installed in a position where they are unlikely to be exposed to any substance which may corrode refrigerant containing components, unless the components are constructed of

materials which are inherently resistant to being corroded or are suitably protected against being so corroded.

### **9. Checks to electrical devices**

Repair and maintenance to electrical components shall include initial safety checks and component inspection procedures. If a fault exists that could compromise safety, then no electrical supply shall be connected to the circuit until it is satisfactorily dealt with. If the fault cannot be corrected immediately but it is necessary to continue operation, an adequate temporary solution shall be used. This shall be reported to the owner of the equipment so all parties are advised. Initial safety checks shall include:

- that capacitors are discharged: this shall be done in a safe manner to avoid possibility of sparking;
- that there no live electrical components and wiring are exposed while charging, recovering or purging the system;
- that there is continuity of earth bonding.

### **10. Repairs to sealed components**

10.1 During repairs to sealed components, all electrical supplies shall be disconnected from the equipment being worked upon prior to any removal of sealed covers, etc. If it is absolutely necessary to have an electrical supply to equipment during servicing, then a permanently operating form of leak detection shall be located at the most critical point to warn of a potentially hazardous situation.

10.2 Particular attention shall be paid to the following to ensure that by working on electrical components, the casing is not altered in such a way that the level of protection is affected. This shall include damage to cables, excessive number of connections, terminals not made to original specification, damage to seals, incorrect fitting of glands, etc.

- Ensure that apparatus is mounted securely.
- Ensure that seals or sealing materials have not degraded such that they no longer serve the purpose of preventing the ingress of

flammable atmospheres. Replacement parts shall be in accordance with the manufacturer's specifications.

NOTE: The use of silicon sealant may inhibit the effectiveness of some types of leak detection equipment. Intrinsically safe components do not have to be isolated prior to working on them.

### **11. Repair to intrinsically safe components**

Do not apply any permanent inductive or capacitance loads to the circuit without ensuring that this will not exceed the permissible voltage and current permitted for the equipment in use. Intrinsically safe components are the only types that can be worked on while live in the presence of a flammable atmosphere. The test apparatus shall be at the correct rating.

Replace components only with parts specified by the manufacturer. Other parts may result in the ignition of refrigerant in the atmosphere from a leak.

### **12. Cabling**

Check that cabling will not be subject to wear, corrosion, excessive pressure, vibration, sharp edges or any other adverse environmental effects. The check shall also take into account the effects of aging or continual vibration from sources such as compressors or fans.

### **13. Detection of flammable refrigerants**

Under no circumstances shall potential sources of ignition be used in the searching for or detection of refrigerant leaks. A halide torch (or any other detector using a naked flame) shall not be used.

### **14. Leak detection methods**

The following leak detection methods are deemed acceptable for systems containing flammable refrigerants. Electronic leak detectors shall be used to detect flammable refrigerants, but the sensitivity may not be adequate, or may need re-calibration. (Detection equipment shall be calibrated in a refrigerant-free area.) Ensure that the detector is not a potential source of ignition and is

suitable for the refrigerant used. Leak detection equipment shall be set at a percentage of the LFL of the refrigerant and shall be calibrated to the refrigerant employed and the appropriate percentage of gas (25 % maximum) is confirmed. Leak detection fluids are suitable for use with most refrigerants but the use of detergents containing chlorine shall be avoided as the chlorine may react with the refrigerant and corrode the copper pipe-work.

If a leak is suspected, all naked flames shall be removed or extinguished.

If a leakage of refrigerant is found which requires brazing, all of the refrigerant shall be recovered from the system, or isolated (by means of shut off valves) in a part of the system

remote from the leak. Oxygen free nitrogen (OFN) shall then be purged through the system both before and during the brazing process.

#### **15. Removal and evacuation**

When breaking into the refrigerant circuit to make repairs or for any other purpose conventional procedures shall be used. However, it is important that best practice is followed since flammability is a consideration. The following procedure shall be adhered to:

- remove refrigerant;
- purge the circuit with inert gas;
- evacuate;
- purge again with inert gas;
- open the circuit by cutting or brazing.

The refrigerant charge shall be recovered into the correct recovery cylinders. The system shall be flushed with OFN to render the unit safe. This process may need to be repeated several times. Compressed air or oxygen shall not be used for this task. Flushing shall be achieved by breaking the vacuum in the system with OFN and continuing to fill until the working pressure is achieved, then venting to atmosphere, and finally pulling down to a vacuum. This process shall be repeated until no refrigerant is within the system. When the final

OFN charge is used, the system shall be vented down to atmospheric pressure to enable work to take place. This operation is absolutely vital if brazing operations on the pipe-work are to take place.

Ensure that the outlet for the vacuum pump is not close to any ignition sources and there is ventilation available.

#### **16. Charging procedures**

In addition to conventional charging procedures, the following requirements shall be followed:

- Ensure that contamination of different refrigerants does not occur when using charging equipment. Hoses or lines shall be as short as possible to minimize the amount of refrigerant contained in them.
- Cylinders shall be kept upright.
- Ensure that the refrigeration system is earthed prior to charging the system with refrigerant.
- Label the system when charging is complete (if not already).
- Extreme care shall be taken not to overfill the refrigeration system.
- Prior to recharging the system it shall be pressure tested with OFN. The system shall be leak tested on completion of charging but prior to commissioning. A follow up leak test shall be carried out prior to leaving the site.

#### **17. Decommissioning**

Before carrying out this procedure, it is essential that the technician is completely familiar with the equipment and all its detail. It is recommended good practice that all refrigerants are recovered safely. Prior to the task being carried out, an oil and refrigerant sample shall be taken.

In case analysis is required prior to re-use of reclaimed refrigerant. It is essential that electrical power is available before the task is commenced.

- a) Become familiar with the equipment and its operation.
- b) Isolate system electrically.
- c) Before attempting the procedure ensure that:



- mechanical handling equipment is available, if required, for handling refrigerant cylinders;
  - all personal protective equipment is available and being used correctly;
  - the recovery process is supervised at all times by a competent person;
  - recovery equipment and cylinders conform to the appropriate standards.
- d) Pump down refrigerant system, if possible.
- e) If a vacuum is not possible, make a manifold so that refrigerant can be removed from various parts of the system.
- f) Make sure that cylinder is situated on the scales before recovery takes place.
- g) Start the recovery machine and operate in accordance with manufacturer's instructions.
- h) Do not overfill cylinders. (No more than 80 % volume liquid charge).
- i) Do not exceed the maximum working pressure of the cylinder, even temporarily.
- j) When the cylinders have been filled correctly and the process completed, make sure that the cylinders and the equipment are removed from site promptly and all isolation valves on the equipment are closed off.
- k) Recovered refrigerant shall not be charged into another refrigeration system unless it has been cleaned and checked.

### **18. Labelling**

Equipment shall be labelled stating that it has been de-commissioned and emptied of refrigerant. The label shall be dated and signed. Ensure that there are labels on the equipment stating the equipment contains flammable refrigerant.

### **19. Recovery**

- When removing refrigerant from a system, either for servicing or decommissioning, it is recommended good practice that all refrigerants are removed safely.
- When transferring refrigerant into cylinders, ensure that only appropriate refrigerant recovery cylinders are employed. Ensure that the correct numbers of cylinders for holding the total system charge are available. All cylinders

to be used are designated for the recovered refrigerant and labelled for that refrigerant (i.e. special cylinders for the recovery of refrigerant). Cylinders shall be complete with pressure relief valve and associated shut-off valves in good working order.

- Empty recovery cylinders are evacuated and, if possible, cooled before recovery occurs.
- The recovery equipment shall be in good working order with a set of instructions concerning the equipment that is at hand and shall be suitable for the recovery of flammable refrigerants. In addition, a set of calibrated weighing scales shall be available and in good working order.
- Hoses shall be complete with leak-free disconnect couplings and in good condition. Before using the recovery machine, check that it is in satisfactory working order, has been properly maintained and that any associated electrical components are sealed to prevent ignition in the event of a refrigerant release. Consult manufacturer if in doubt.
- The recovered refrigerant shall be returned to the refrigerant supplier in the correct recovery cylinder, and the relevant Waste Transfer Note arranged. Do not mix refrigerants in recovery units and especially not in cylinders.
- If compressors or compressor oils are to be removed, ensure that they have been evacuated to an acceptable level to make certain that flammable refrigerant does not remain within the lubricant. The evacuation process shall be carried out prior to returning the compressor to the suppliers. Only electric heating to the compressor body shall be employed to accelerate this process. When oil is drained from a system, it shall be carried out safely.

### 3. Model List

#### Model Names of Indoor/Outdoor Units

	Capacity	Indoor units	Outdoor units
3D inverter	9k	MSMBBU-09HRFN8-QRD6GW	MOB01-09HFN8-QRD6GW
	12k	MSMBBU-12HRFN8-QRD6GW	MOB01-12HFN8-QRD6GW
	18k	MSMBCU-18HRFN8-QRD0GW	MOB02-18HFN8-QRD0GW
	24k	MSMBDU-24HRFN8-QRD0GW	MOCA01-24HFN8-QRD0GW

## 4. Dimension

### 4.1 Indoor Unit

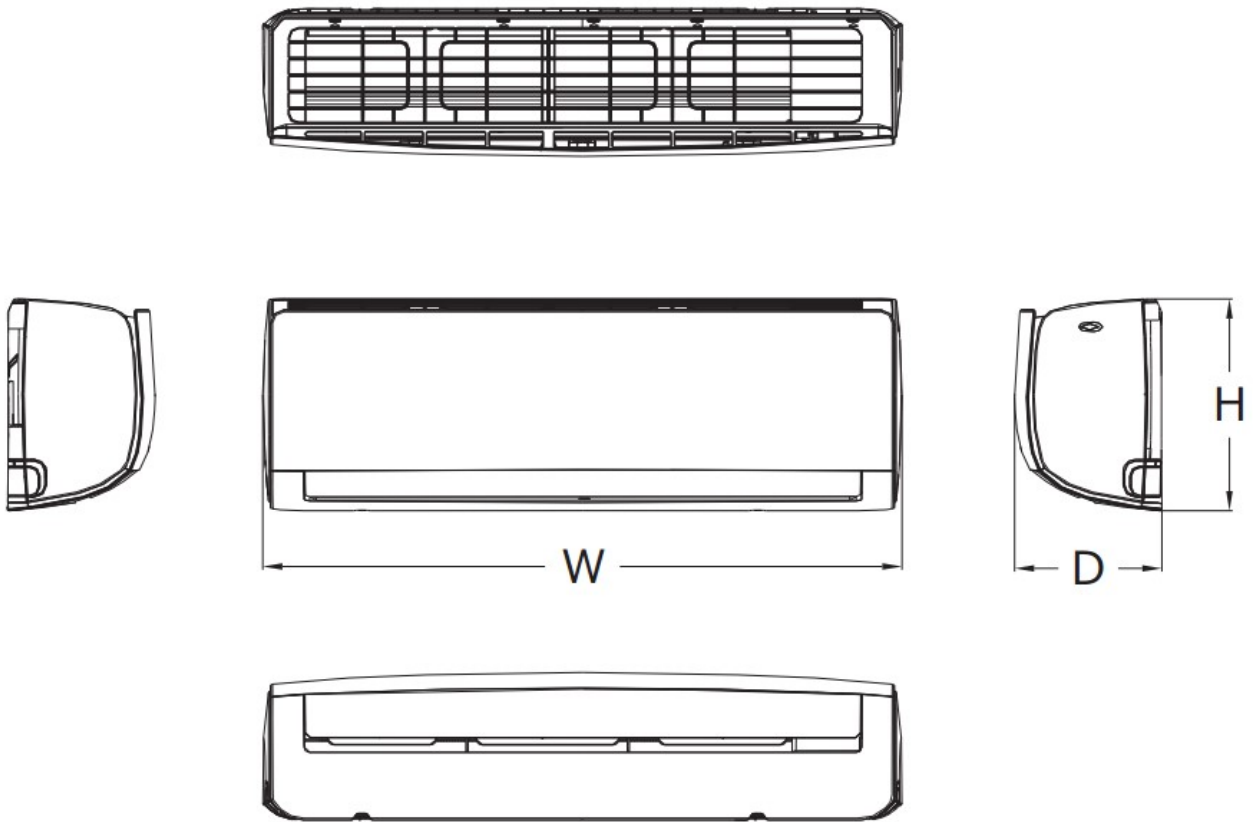

Model	W	D	H
MSMBBU-09HRFN8-QRD6GW	810	200	300
MSMBBU-12HRFN8-QRD6GW	810	200	300
MSMBCU-18HRFN8-QRD0GW	980	225	325
MSMBDU-24HRFN8-QRD0GW	1090	235	338

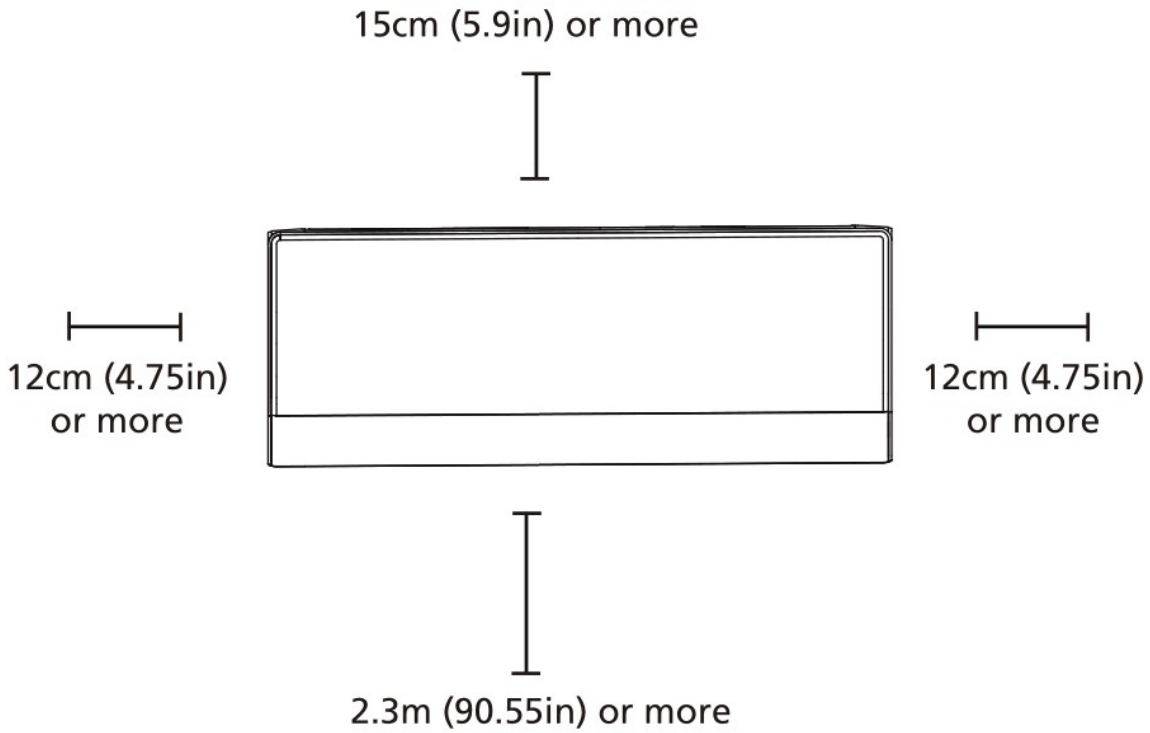

For MSMBBU-09HRFN8-QRD6GW, MSMBBU-12HRFN8-QRD6GW

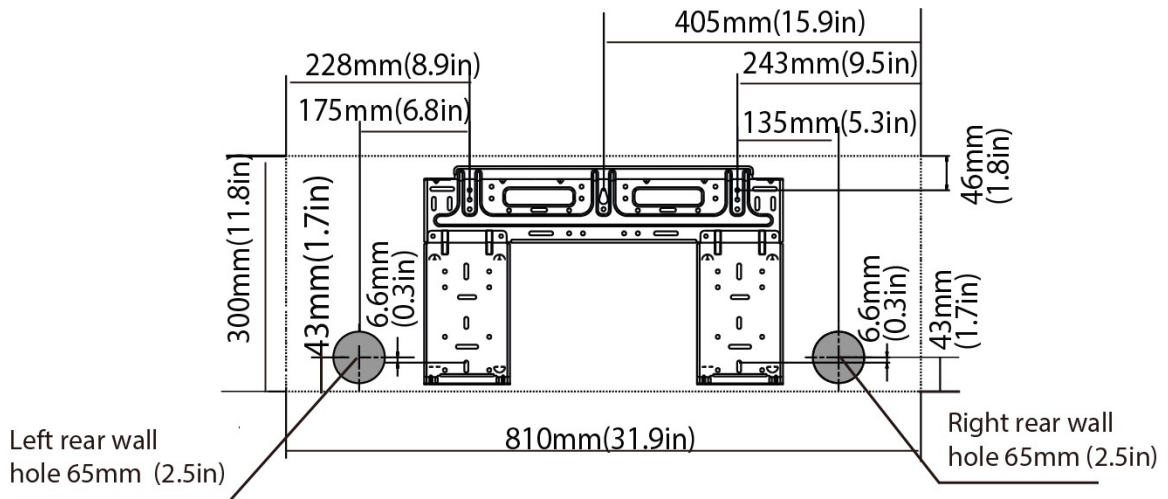

Model B

For MSMBCU-18HRFN8-QRD0GW,

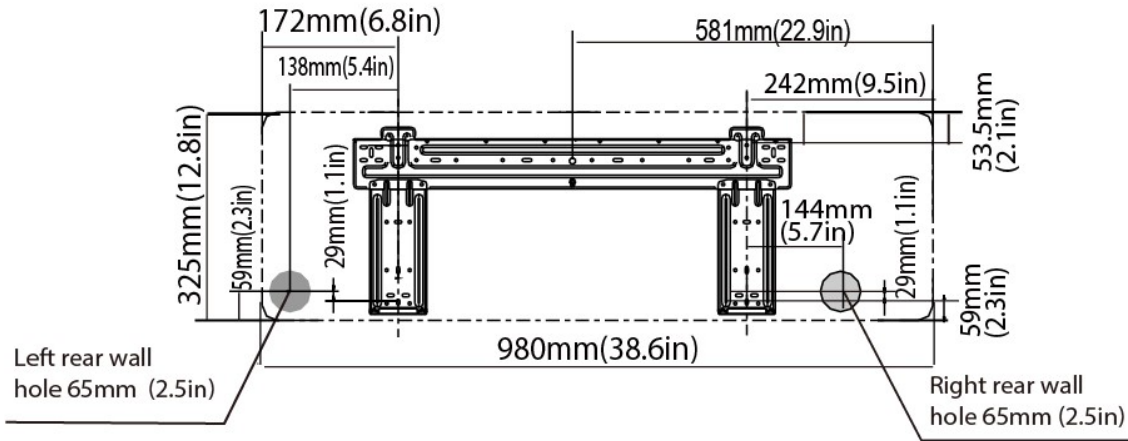

Model C

For MSMBDU-24HRFN8-QRD0GW

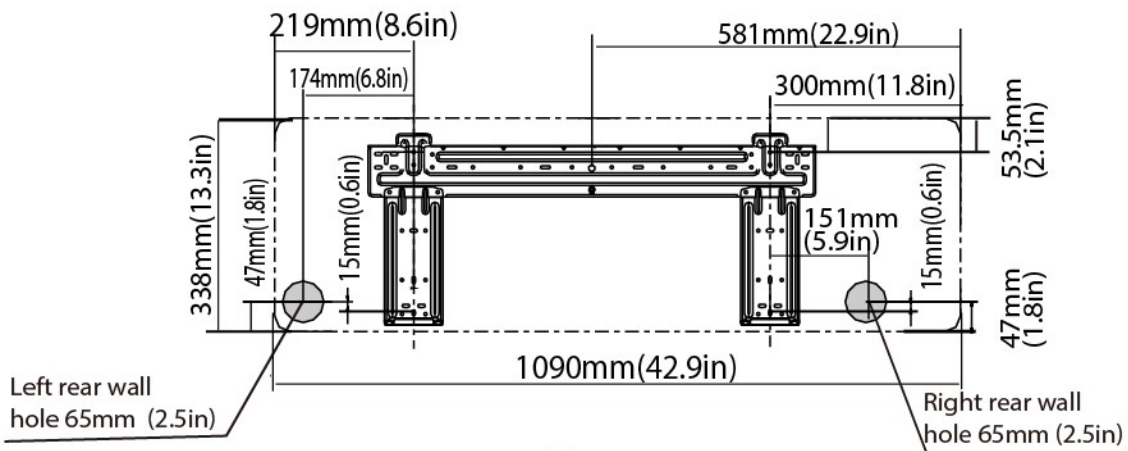

Model D

## 4.2 Outdoor Unit

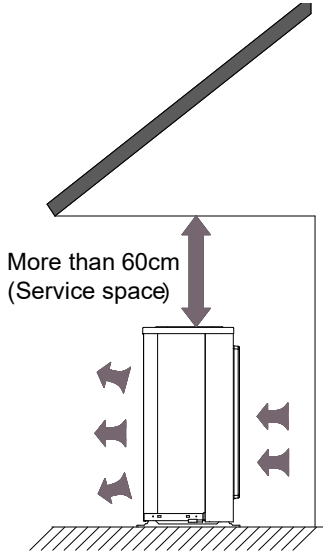
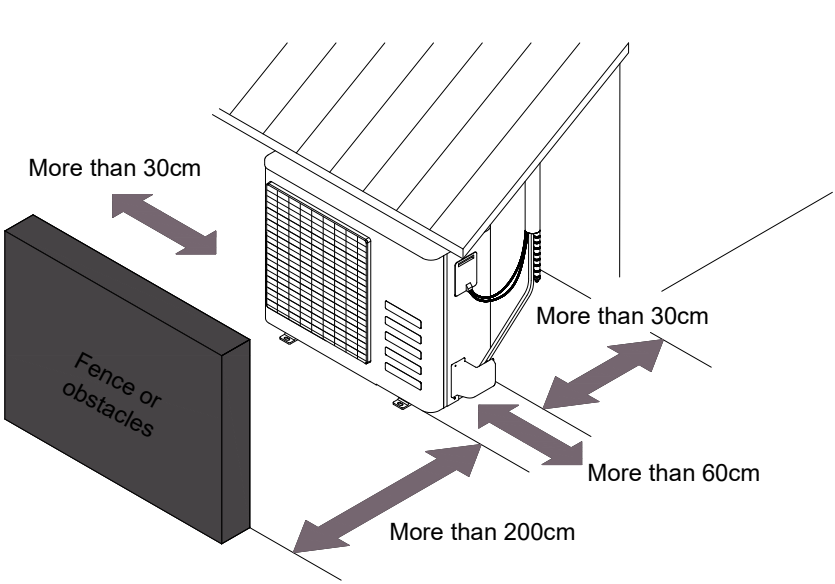

For MOB01-09HFN8-QRD6GW, MOB01-12HFN8-QRD6GW, MOB02-18HFN8-QRD0GW

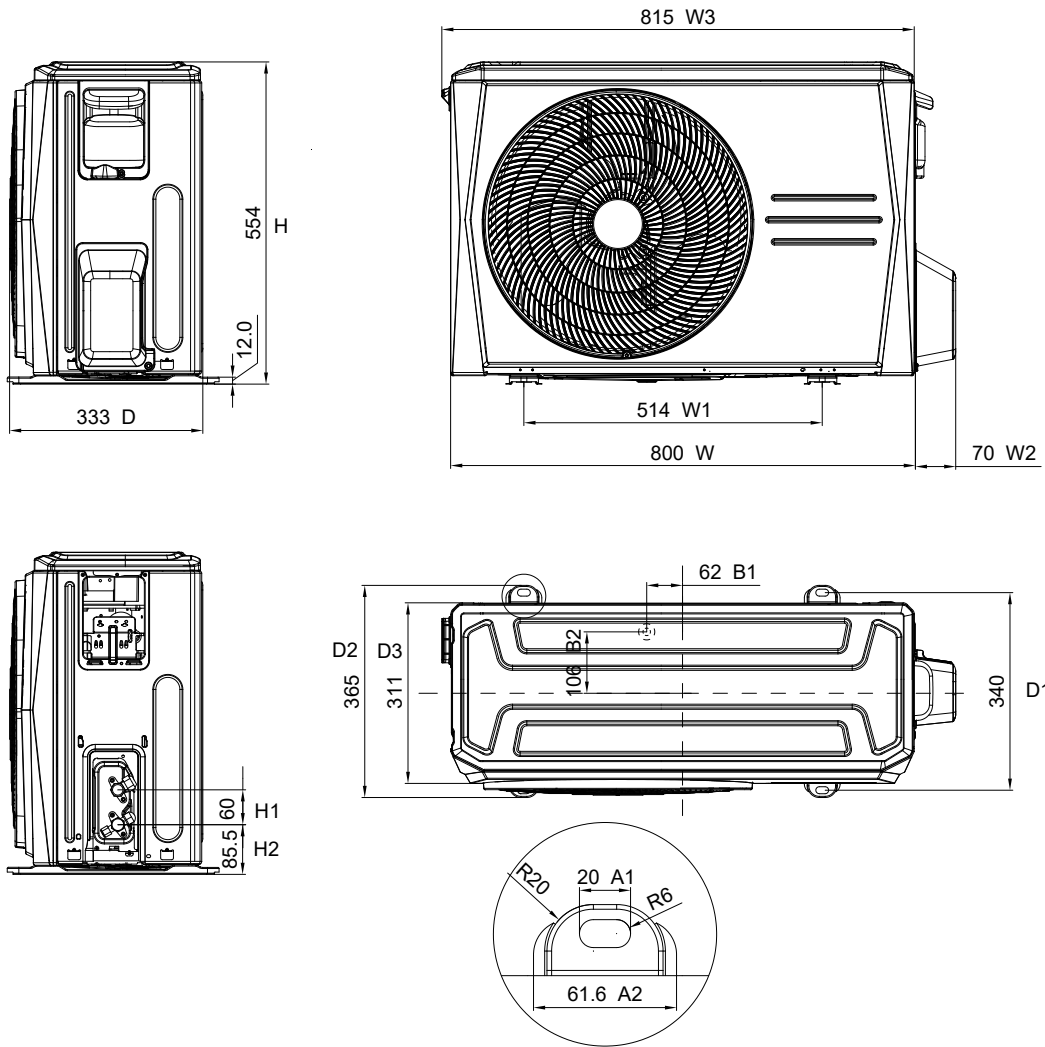

For MOCA01-24HFN8-QRD0GW

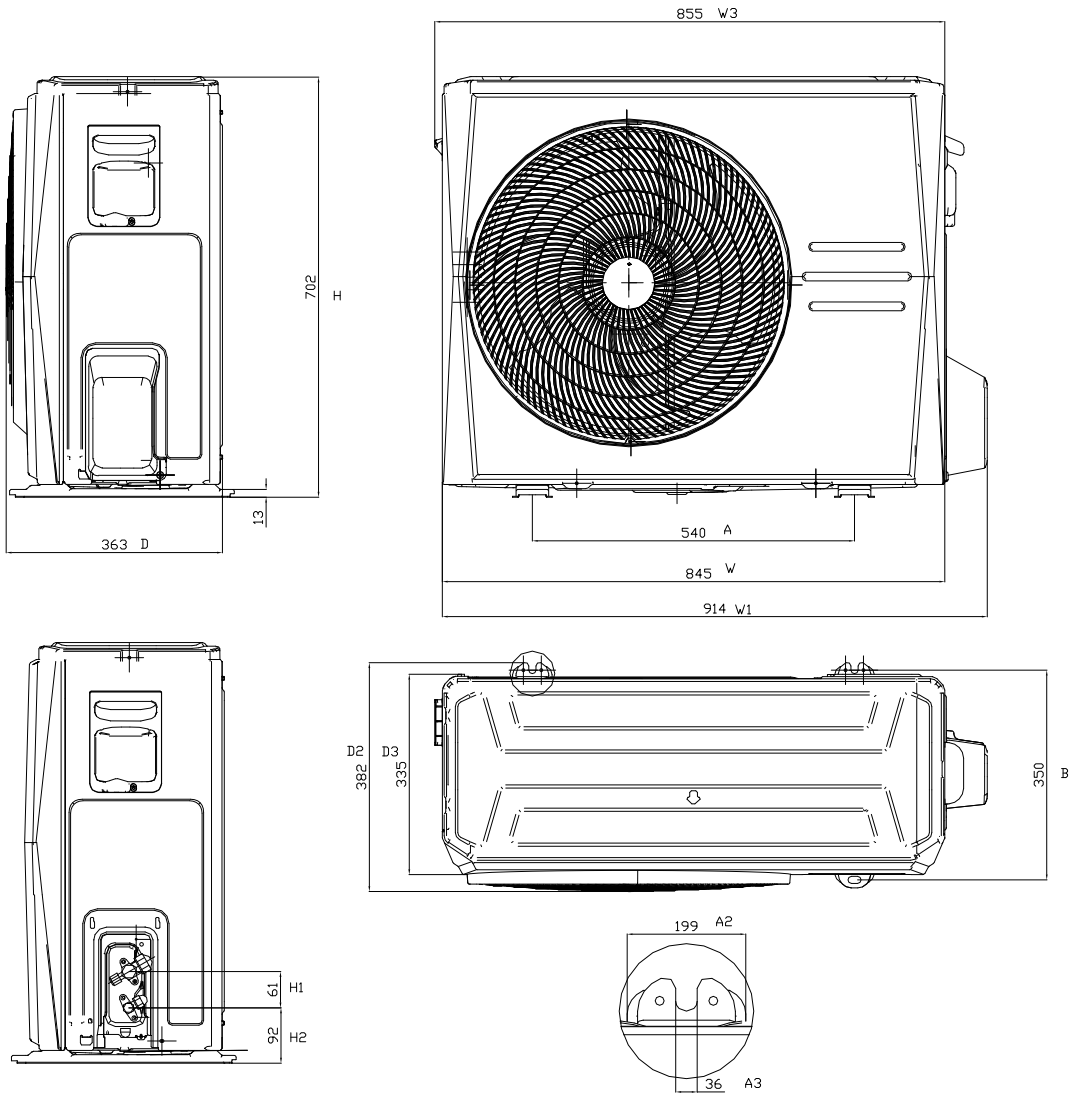



## 5. Refrigerant Cycle Diagram

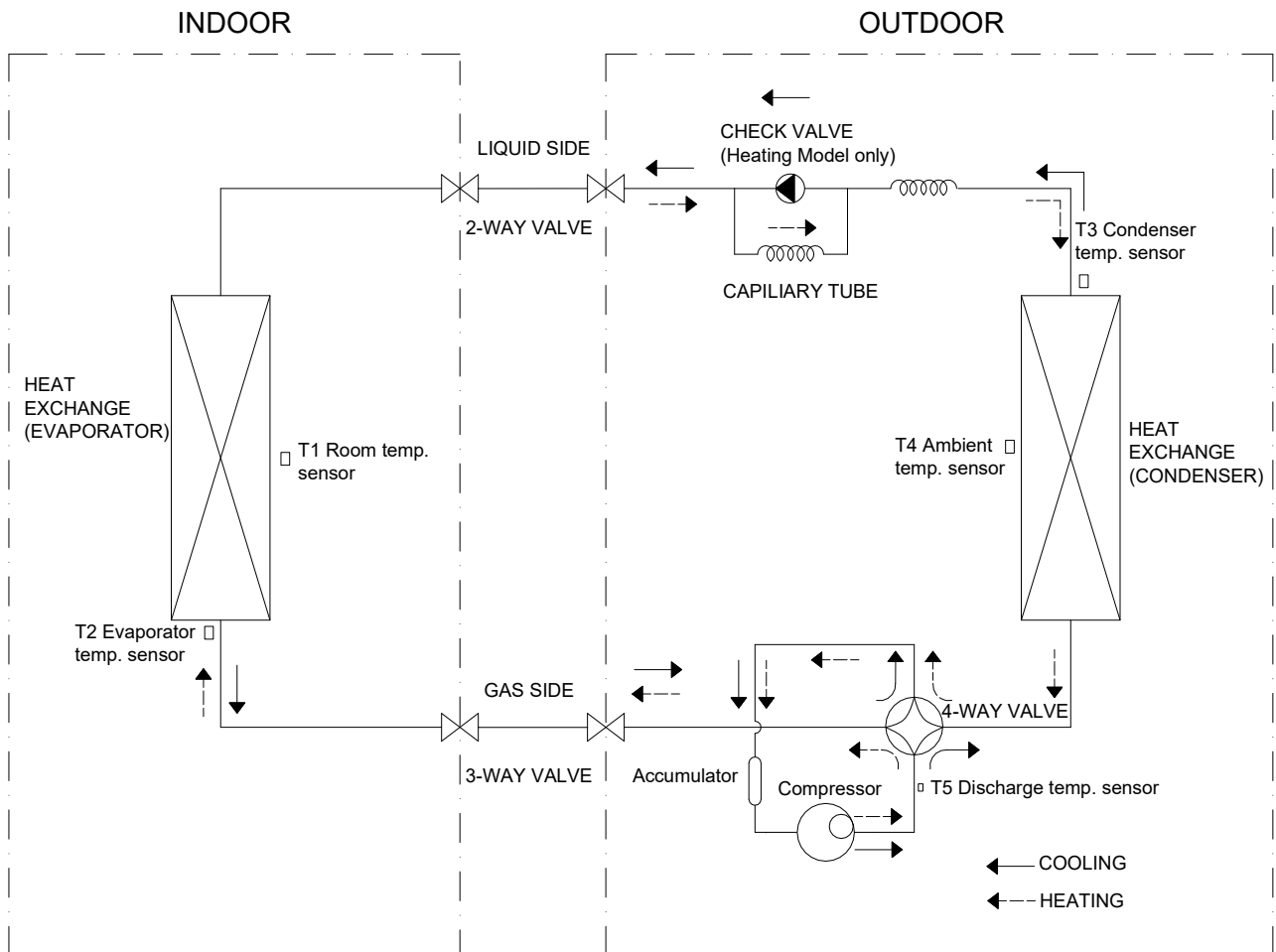

## 6 Installation Details

### 6.1 Wrench torque sheet for installation

Outside diameter		Torque	Additional tightening torque
mm	inch	N.cm	N.cm
Φ6.35	1/4	1500(153kgf.cm)	1600(163kgf.cm)
Φ9.52	3/8	2500(255kgf.cm)	2600(265kgf.cm)
Φ12.7	1/2	3500(357kgf.cm)	3600(367kgf.cm)
Φ15.9	5/8	4500(459kgf.cm)	4700(479kgf.cm)
Φ19	3/4	6500(663kgf.cm)	6700(683kgf.cm)

### 6.2 Connecting the cables

The power cord of connect should be selected according to the following specifications sheet.

Rated current of appliance	Nominal cross-sectional area (mm <sup>2</sup> )
>3 and ≤6	0.75
>6 and ≤10	1
>10 and ≤16	1.5
>16 and ≤25	2.5

The cable size and the current of the fuse or switch are determined by the maximum current indicated on the nameplate which located on the side panel of the unit. Please refer to the nameplate before selecting the cable, fuse and switch.

### 6.3 Pipe length and the elevation

The pipe length and refrigerant amount:

Model	Pipe size		Standard length (m)	Max. Elevation B (m)	Max. Length A (m)	Additional refrigerant (g/m)
	Gas	Liquid				
MSMBBU-09HRFN8-QRD6GW+MOB01-09HFN8-QRD6GW	3/8" (Φ9.52)	1/4" (Φ6.35)	5	10	25	12
MSMBBU-12HRFN8-QRD6GW+MOB01-12HFN8-QRD6GW	3/8" (Φ9.52)	1/4" (Φ6.35)	5	10	25	12
MSMBCU-18HRFN8-QRD0GW+MOB02-18HFN8-QRD0GW	1/2" (Φ12.7)	1/4" (Φ6.35)	5	20	30	12
MSMBDU-24HRFN8-QRD0GW+MOCA01-24HFN8-QRD0GW W	5/8" (Φ15.9)	3/8" (Φ9.52)	5	25	50	24

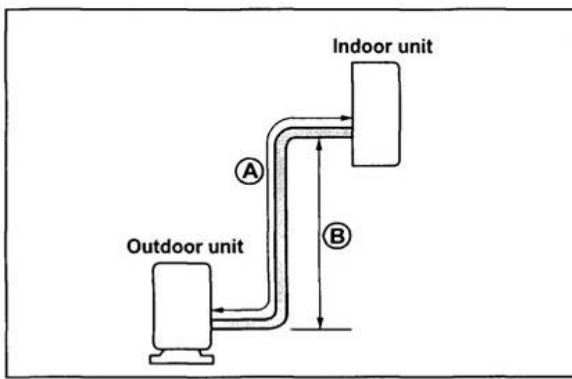

**Caution:**

The capacity test is based on the standard length and the maximum permissible length is based on the system reliability.

## 6.4 Installation for the first time

Air and moisture in the refrigerant system have undesirable effects as below:

- Pressure in the system rises.
- Operating current rises.
- Cooling or heating efficiency drops.
- Moisture in the refrigerant circuit may freeze and block capillary tubing.
- Water may lead to corrosion of parts in the refrigerant system.

Therefore, the indoor units and the pipes between indoor and outdoor units must be leak tested and evacuated to remove gas and moisture from the system.

Gas leak check (Soap water method):

Apply soap water or a liquid neutral detergent on the indoor unit connections or outdoor unit connections by a soft brush to check for leakage of the connecting points of the piping. If bubbles come out, the pipes have leakage.

### 1. Air purging with vacuum pump

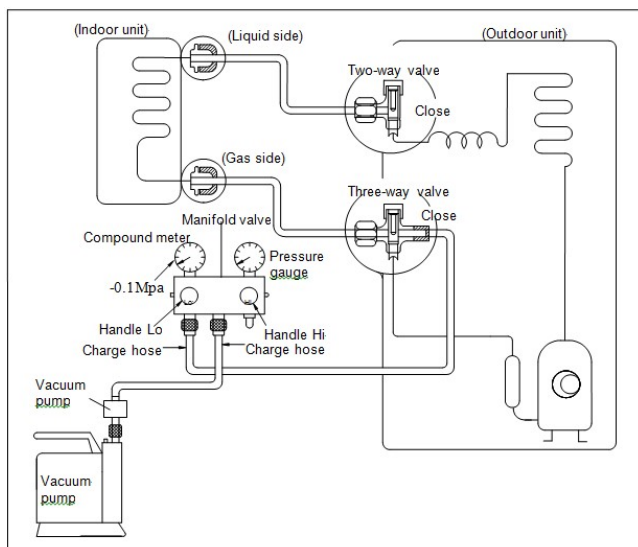

- 1) Completely tighten the flare nuts of the indoor and outdoor units, confirm that both the 2-way and 3-way valves are set to the closed position.
- 2) Connect the charge hose with the push pin of handle lo to the 3-way valves gas service port..
- 3) Connect the charge hose of handle hi

connection to the vacuum pump.

- 4) Fully open the handle Lo of the manifold valve.
- 5) Operate the vacuum pump to evacuate.
- 6) Make evacuation for 30 minutes and check whether the compound meter indicates  $-0.1\text{Mpa}$ . If the meter does not indicate  $-0.1\text{Mpa}$  after pumping 30 minutes, it should be pumped 20 minutes more. If the pressure can't achieve  $-0.1\text{Mpa}$  after pumping 50 minutes, please check if there are some leakage points.

Fully close the handle Lo valve of the manifold valve and stop the operation of the vacuum pump. Confirm that the gauge needle does not move (approximately 5 minutes after turning off the vacuum pump).

- 7) Turn the flare nut of the 3-way valves about  $45^\circ$  counterclockwise for 6 or 7seconds after the gas

coming out, then tighten the flare nut again. Make sure the pressure display in the pressure indicator is a little higher than the atmosphere pressure. Then remove the charge hose from the 3 way valve.

- 8) Fully open the 2 way valve and 3 way valve and securely tighten the cap of the 3 way valve.

### 2. Adding the refrigerant if the pipe length $>5\text{m}$

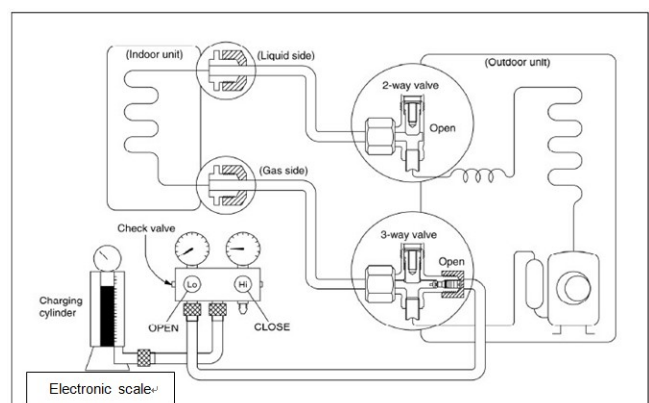

#### Procedure:

- 1). Connect the charge hose to the charging cylinder, open the 2-way valve and the 3-way valve.

Connect the charge hose which you

disconnected from the vacuum pump to the valve at the bottom of the cylinder. If the refrigerant is R410A, make the cylinder bottom up to ensure the liquid charge.

- 2). Purge the air from the charge hose.  
Open the valve at the bottom of the cylinder and press the check valve on the charge set to purge the air (be careful of the liquid refrigerant).
- 3) Put the charging cylinder onto the electronic scale and record the weight.
- 4) Operate the air conditioner at the cooling mode.
- 5) Open the valves (Low side) on the charge set and charge the system with liquid refrigerant.
- 6).When the electronic scale displays the proper weight (refer to the table), disconnect the charge hose from the 3-way valve's service port immediately and turn off the air conditioner before disconnecting the hose.
- 7). Mount the valve stem caps and the service port  
Use torque wrench to tighten the service port cap to a torque of 18N.m.  
Be sure to check for gas leakage.

### 6.5 Adding the refrigerant after running the system for many years

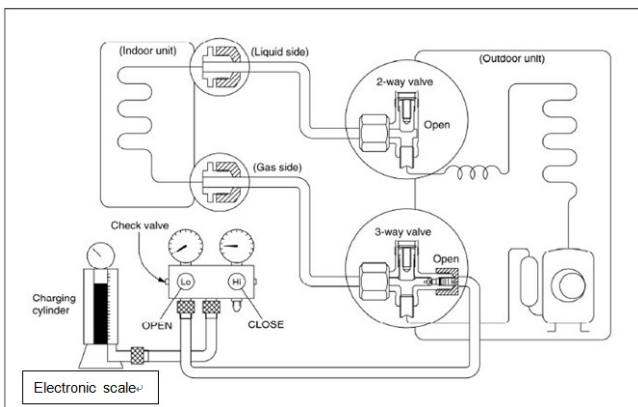

#### Procedure:

- 1). Connect the charge hose to the 3-way service port, open the 2-way valve and the 3-way valve. Connect the charge hose to the valve at the bottom of the cylinder. If the refrigerant is R410A, make the cylinder bottom up to ensure

liquid charge.

- 2). Purge the air from the charge hose.  
Open the valve at the bottom of the cylinder and press the check valve on the charge set to purge the air (be careful of the liquid refrigerant).
- 3) Put the charging cylinder onto the electronic scale and record the weight.
- 4) Operate the air conditioner at the cooling mode.
- 5) Open the valves (Low side) on the charge set and charge the system with liquid refrigerant.
- 6).When the electronic scale displays the proper weight (refer to the gauge and the pressure of the low side), disconnect the charge hose from the 3-way valve's service port immediately and turn off the air conditioner before disconnecting the hose.
- 7). Mount the valve stem caps and the service port  
Use torque wrench to tighten the service port cap to a torque of 18N.m.  
Be sure to check for gas leakage.

### 6.6 Re-installation while the indoor unit need to be repaired

#### 1. Collecting the refrigerant into the outdoor unit

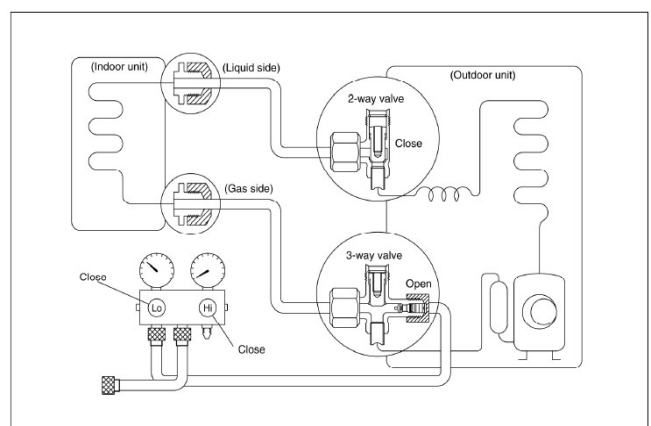

#### Procedure

- 1). Confirm that both the 2-way and 3-way valves are set to the opened position  
Remove the valve stem caps and confirm that the valve stems are in the opened position.

Be sure to use a hexagonal wrench to operate the valve stems.

2). Connect the charge hose with the push pin of handle lo to the 3-way valves gas service port.

3). Air purging of the charge hose.

Open the handle Lo valve of the manifold valve slightly to purge air from the charge hose for 5 seconds and then close it quickly.

4). Set the 2-way valve to the close position.

5). Operate the air conditioner at the cooling cycle and stop it when the gauge indicates 0.1MPa.

6). Set the 3-way valve to the closed position immediately

Do this quickly so that the gauge ends up indicating 0.3 to 0.5Mpa.

Disconnect the charge set, and tighten the 2-way and 3-way valve's stem nuts.

Use a torque wrench to tighten the 3-way valves service port cap to a torque of 18N.m.

Be sure to check for gas leakage.

## 2. Air purging with vacuum pump

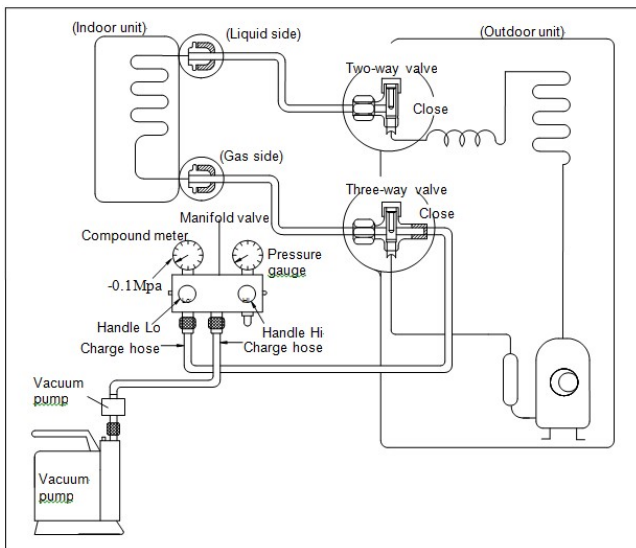

- 1) Completely tighten the flare nuts of the indoor and outdoor units, confirm that both the 2-way and 3-way valves are set to the closed position.
- 2) Connect the charge hose with the push pin of handle lo to the 3-way valves gas service port.
- 3) Connect the charge hose of handle hi connection to the vacuum pump.
- 4) Fully open the handle Lo of the manifold

valve.

5) Operate the vacuum pump to evacuate.

6) Make evacuation for 30 minutes and check whether the compound meter indicates -0.1Mpa. If the meter does not indicate -0.1Mpa after pumping 30 minutes, it should be pumped 20 minutes more. If the pressure can't achieve -0.1Mpa after pumping 50 minutes, please check if there are some leakage points. Fully close the handle Lo valve of the manifold valve and stop the operation of the vacuum pump. Confirm that the gauge needle does not move (approximately 5 minutes after turning off the vacuum pump).

7) Turn the flare nut of the 3-way valves about 45° counterclockwise for 6 or 7 seconds after the gas coming out, then tighten the flare nut again. Make sure the pressure display in the pressure indicator is a little higher than the atmosphere pressure. Then remove the charge hose from the 3 way valve.

8) Fully open the 2 way valve and 3 way valve and securely tighten the cap of the 3 way valve.

## 6.7 Re-installation while the outdoor unit need to be repaired

### 1. Evacuation for the whole system

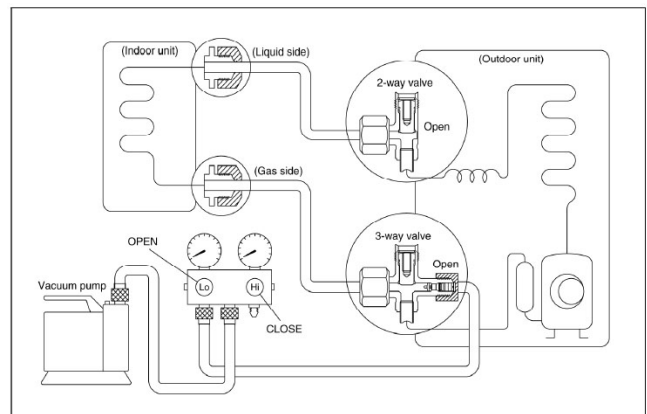

#### Procedure:

- 1). Confirm that both the 2-way and 3-way valves are set to the opened position.
- 2). Connect the vacuum pump to 3-way valve's service port.
- 3). Evacuation for approximately one hour.

Confirm that the compound meter indicates -0.1Mpa.

4). Close the valve (Low side) on the charge set, turn off the vacuum pump, and confirm that the gauge needle does not move (approximately 5 minutes after turning off the vacuum pump).

5). Disconnect the charge hose from the vacuum pump.

## 2. Refrigerant charging

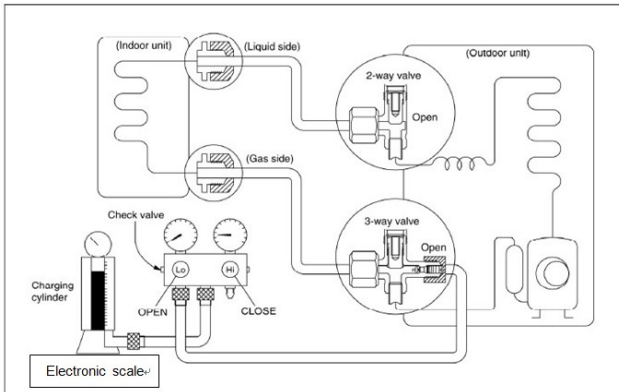

### Procedure:

1). Connect the charge hose to the charging cylinder, open the 2-way valve and the 3-way valve

Connect the charge hose which you disconnected from the vacuum pump to the valve at the bottom of the cylinder. If the refrigerant is R410A, make the cylinder bottom up to ensure liquid charge.

2). Purge the air from the charge hose  
Open the valve at the bottom of the cylinder and press the check valve on the charge set to purge the air (be careful of the liquid refrigerant).

3) Put the charging cylinder onto the electronic scale and record the weight.

4). Open the valves (Low side) on the charge set and charge the system with liquid refrigerant

If the system cannot be charge with the specified amount of refrigerant, or can be charged with a little at a time (approximately 150g each time) , operating the air conditioner in the cooling cycle; however, one time is not sufficient, wait approximately 1 minute and then repeat the procedure.

5).When the electronic scale displays the proper weight, disconnect the charge hose from the 3-way valve's service port immediately

If the system has been charged with liquid refrigerant while operating the air conditioner, turn off the air conditioner before disconnecting the hose.

6). Mounted the valve stem caps and the service port. Use torque wrench to tighten the service port cap to a torque of 18N.m.

Be sure to check for gas leakage

## 7. Operation Characteristics

Mode Temperature	Cooling operation	Heating operation	Drying operation
Room temperature	16°C~32°C (60°F~90°F)	0°C~30°C (32°F~86°F)	10°C~32°C (50°F~90°F)
Outdoor temperature	0°C~50°C (32°F~122°F)	-15°C~30°C (5°F~86°F)	0°C~50°C (32°F~122°F)
	-15°C~50°C (5°F~122°F) (For the models with low temperature cooling system)		

### CAUTION:

1. If the air conditioner is used beyond the above conditions, certain safety protection features may come into operation and cause the unit to operate abnormally.
2. The room relative humidity should be less than 80%. If the air conditioner operates beyond this figure, the surface of the air conditioner may attract condensation. Please set the vertical air flow louver to its maximum angle (vertically to the floor), and set HIGH fan mode.
3. The optimum performance will be achieved during this operating temperature zone.



# 8. Wiring Diagram

## 8.1 Indoor Unit

MSMBBU-09HRFN8-QRD6GW, MSMBBU-12HRFN8-QRD6GW, MSMBUCU-18HRFN8-QRD0GW  
MSMBDU-24HRFN8-QRD0GW

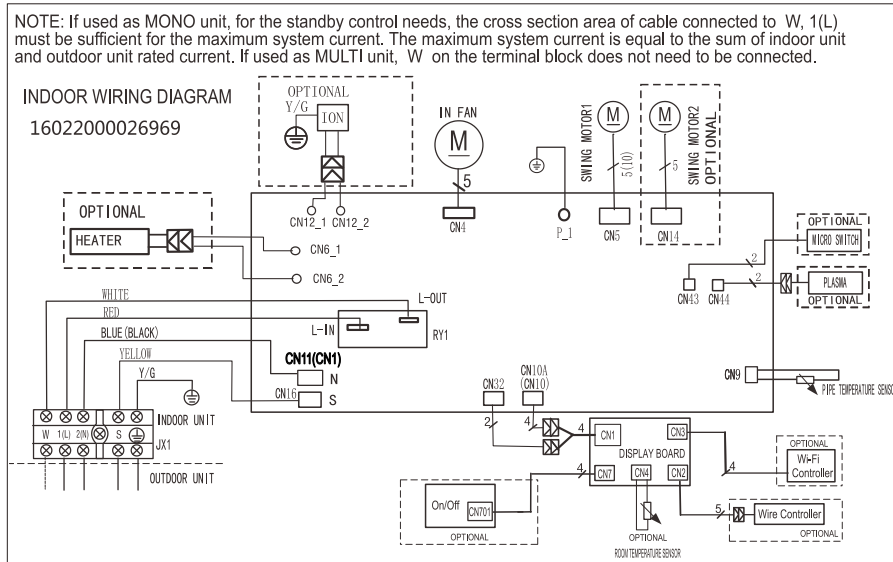

## 8.2 Outdoor Unit

MOB01-09HFN8-QRD6GW, MOB01-12HFN8-QRD6GW

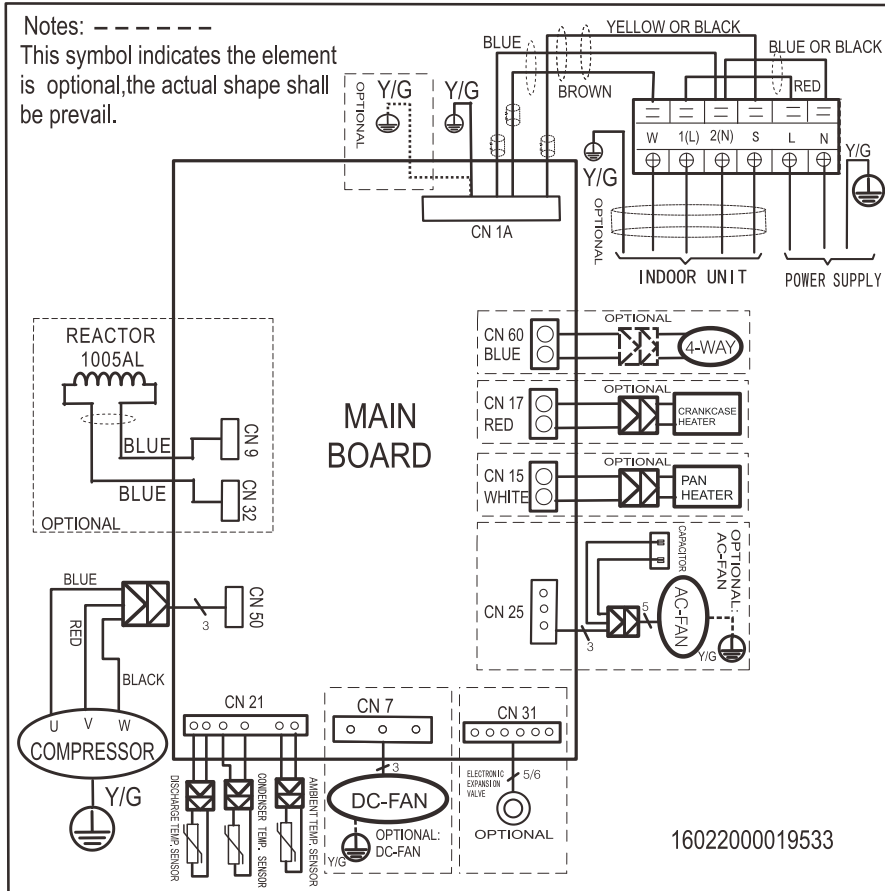

MOB02-18HFN8-QRD0GW, MOCA01-24HFN8-QRD0GW

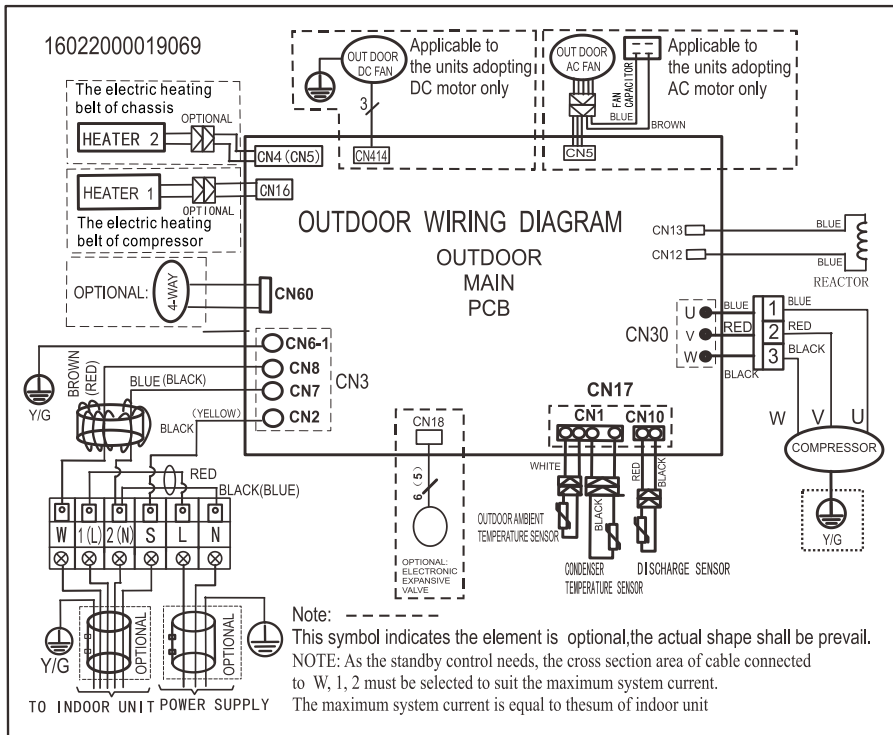

## 9. Electronic function

### 9.1 Abbreviation

- T1: Indoor room temperature  
T2: Coil temperature of evaporator  
T3: Coil temperature of condenser  
T4: Outdoor ambient temperature  
T5: Compressor discharge temperature  
Tsc: Adjusted setting temperature

### 9.2 Display function

#### 9.2.1 Icon explanation on indoor display board.



Digital display:

Displays temperature, operation feature and Error codes.

In Fan mode, the unit will display the room temperature.

In other modes, the unit will display your temperature setting.

Displays 'ON' for three seconds when Timer ON, Fresh, Swing, Turbo or Silence feature is activated.

Displays 'OF' for three seconds when Timer OFF is set. Fresh, Swing, Turbo or Silence

feature is cancelled.

Displays 'DF' under defrosting operation.

Displays 'CF' when anti-cold air feature is activated under heating mode.

Displays 'SC' during self clean operation (if applicable).

Displays 'FP' when freeze protection is turned on (some units).

Displays 'leaf' when fresh feature is turned on (some units)

Displays 'eco' when ECO feature is activated (some units)



WiFi control display (optional)

Displays when wireless control feature is activated (some units)

'kW' Indicates the current operation power

NOTE:

A guide on using the infrared remote is not included in this literature package.

## **9.3 Main Protection**

### **9.3.1 Compressor three-minute delay at restart**

Compressor functions are delayed for up to ten seconds upon the first startup of the unit, and are delayed for up to three minutes upon subsequent unit restarts.

### **9.3.2 Automatic shutoff based on discharge temperature**

If the compressor discharge temperature exceeds 108°C for nine seconds, the compressor ceases operation.

### **9.3.3 Automatic shutoff based on fan speed**

If the indoor fan speed registers below 200RPM or over 2100RPM for an extended period of time, the unit ceases operation.

### **9.3.4 Inverter module protection**

The inverter module has an automatic shutoff mechanism based on the unit's current, voltage, and temperature. If automatic shutoff is initiated, the corresponding error code is displayed on the indoor unit and the unit ceases operation.

### **9.3.5 Indoor fan delayed operation**

When the unit starts, the louver is automatically activated and the indoor fan will operate after a period of setting time or the louver is in place.

If the unit is in heating mode, the indoor fan is regulated by the anti-cold wind function.

### **9.3.6 Compressor preheating**

Preheating is automatically activated when T4 sensor is lower than setting temperature..

### **9.3.7 Sensor redundancy and automatic shutoff**

If one temperature sensor malfunctions, the air

conditioner continues operation and displays the corresponding error code, allowing for emergency use.

When more than one temperature sensor is malfunctioning, the air conditioner ceases operation.

## 9.4 Operation Modes and Functions

### 9.4.1 Fan mode

1. When fan mode is activated:

- The outdoor fan and compressor are stopped.
- Temperature control is disabled and indoor room temperature is displayed.
- The indoor fan speed can be set to 1%~100%, or auto.
- The louver operations are identical to those in cooling mode.
- Auto fan: In fan mode, AC operates the same as auto fan in cooling mode with the temperature set at 24°C.(Tsc =24°C)

### 9.4.2 Cooling Mode

#### 9.4.2.1 Compressor Control

1. Reach the configured temperature

1.1 When the compressor runs continuously for less than 120 minutes.

1.1.1 If the following conditions are satisfied, the compressor ceases operation.

- While calculated frequency(fb) is less than minimum limit frequency(FminC).
- While protective time is more than or equal to ten minutes.
- While T1 is lower than or equal to (Tsc-CDIFTEMP-0.5°C)

1.2 When the compressor runs continuously for more than 120 minutes.

1.2.1 If the following conditions are satisfied, the compressor ceases operation.

- When calculated frequency(fb) is less than minimum limit frequency(FminC).
- When protective time is more than or equal

to ten minutes.

- When T1 is lower than or equal to (Tsc-CDIFTEMP).

1.3 If one of the following conditions is satisfied, not judge protective time.

- Compressor running frequency is more than test frequency.
- When compressor running frequency is equal to test frequency, T4 is more than 15°C or no T4 or T4 fault.
- Change setting temperature.
- Turbo or sleep function on/off
- Various frequency limit shutdown occurs.

Note: CDIFTEMP is EEPROM setting parameter. It is 2°C usually.

#### 9.4.2.2 Outdoor Fan Control

The outdoor unit operates at different fan speeds based on T4 and compressor running frequency. The actual speed varies between different outdoor units.

#### 9.4.2.3 Indoor Fan Control

1. In cooling mode, the indoor fan operates continuously. The fan speed can be set to 1%-100%, or auto.

2. Auto fan

2.1 Descent curve

-When T1-Tsc is lower than or equal to 3.5°C, fan speed reduces to 80%;

-When T1-Tsc is lower than or equal to 1°C, fan speed reduces to 60%;

-When T1-Tsc is lower than or equal to 0.5°C,

fan speed reduces to 40%;

-When T1-Tsc is lower than or equal to 0°C, fan speed reduces to 20%;

-When T1-Tsc is lower than or equal to -0.5°C, fan speed reduces to 1%.

#### 2.2 Rise curve

-When T1-Tsc is higher than 0°C, fan speed increases to 20%;

-When T1-Tsc is higher than 0.5°C, fan speed increases to 40%;

-When T1-Tsc is higher than 1°C, fan speed increases to 60%;

-When T1-Tsc is higher than 1.5°C, fan speed increases to 80%;

-When T1-Tsc is higher than 4°C, fan speed increases to 100%.

#### 9.4.2.4 Condenser Temperature Protection

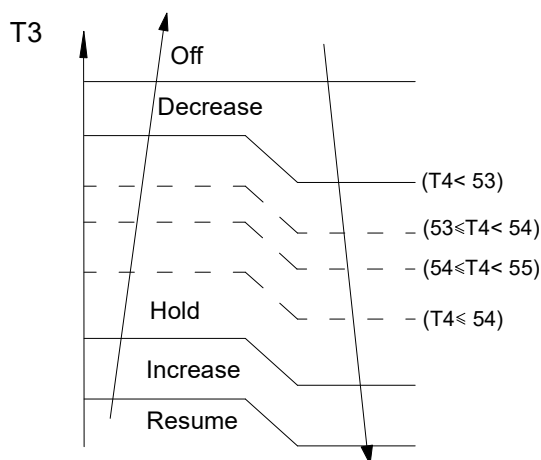

When the condenser temperature exceeds a configured value, the compressor ceases operations.

#### 9.4.2.5 Evaporator Temperature Protection

When evaporator temperature drops below a configured value, the compressor ceases operations.

### 9.4.3 Heating Mode

#### 9.4.3.1 Compressor Control

1. Reach the configured temperature

1.1 If the following conditions are satisfied, the compressor ceases operation.

- While calculated frequency(fb) is less than minimum limit frequency(FminC).
- When protective time is more than or equal to ten minutes.
- When T1 is higher than or equal to Tsc+ HDIFTEMP2

(Note: HDIFTEMP2 is EEPROM setting parameter. It is 2°C usually.)

If one of the following conditions is satisfied, not judge protective time.

- Compressor running frequency is more than test frequency.
- When compressor running frequency is equal to test frequency, T4 is more than 15°C or no T4 or T4 fault.
- Change setting temperature.
- Turbo or sleep function on/off

2. When the current is higher than the predefined safe value, surge protection is activated, causing the compressor to cease operations.

#### 9.4.3.2 Outdoor Fan Control

The outdoor unit operates at different fan speeds based on T4 and compressor running frequency. The actual speed varies between different outdoor units.

#### 9.4.3.3 Indoor Fan Control

1. In heating mode, the indoor fan operates

continuously. The fan speed can be set to 1%-100%, or mute.

## 2. Auto fan

### 2.1 Rise curve

- When T1-Tsc is higher than -1.5°C, fan speed reduces to 80%;
- When T1-Tsc is higher than 0°C, fan speed reduces to 60%;
- When T1-Tsc is higher than 0.5°C, fan speed reduces to 40%;
- When T1-Tsc is higher than 1°C, fan speed reduces to 20%.

### 2.2 Descent curve

- When T1-Tsc is lower than or equal to 0.5°C, fan speed increases to 20%;
- When T1-Tsc is lower than or equal to 0°C, fan speed increases to 60%;
- When T1-Tsc is lower than or equal to -1.5°C, fan speed increases to 80%;
- When T1-Tsc is lower than or equal to -3°C, fan speed increases to 100%.

#### 9.4.3.4 Defrosting mode

The unit enters defrosting mode according to changes in the temperature value of T3, T4 and the compressor running time.

In defrosting mode, the compressor continues to run, the indoor and outdoor motor will cease operation, the defrost light of the indoor unit will

turn on, and the **DF** symbol is displayed.

.If any one of the following condition is satisfied, defrosting ends and the machine switches to normal heating mode:

----T3 rises above TCDE1°C.

----T3 maintained above TCDE2°C for 80 seconds.

----Unit runs for 15 minutes consecutively in defrosting mode.

#### 9.4.3.5 Evaporator Coil Temperature Protection

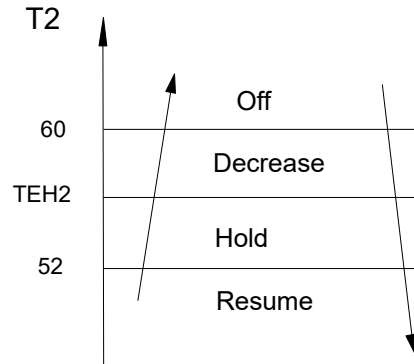

Off: Compressor stops.

Decrease: Decrease the running frequency to the lower level per 20 seconds.

Hold: Keep the current frequency.

Resume: No limitation for frequency.

#### 9.4.4 Auto-mode

This mode can be selected with the remote controller and the temperature setting can be adjusted between 16°C~30°C.

In auto mode, the machine selects cooling, heating, auto-drying or fan-only mode on the basis of T1, Ts, T4 and relative humidity(  $\phi$  ).

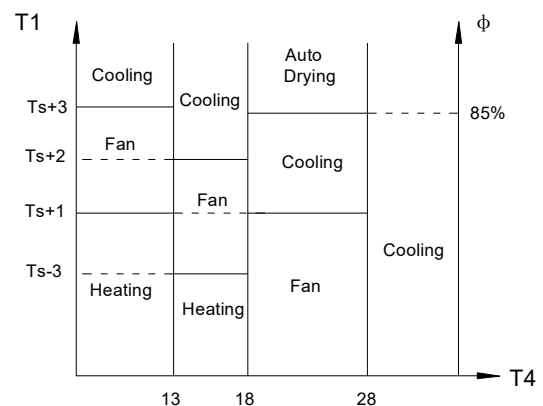

If the setting temperature is modified, the machine selects a new running function.

### 9.4.5 Drying Mode

In drying mode, AC operates the same as auto fan in cooling mode.

Mute function is active.

All protections are activated and operate the same as they do that in cooling mode.

Low Room Temperature Protection

-If the room temperature is lower than 10°C, the compressor ceases operations and does not resume until room temperature exceeds 12°C

### 9.4.6 Forced Operation

1. Forced cooling mode:

The compressor and outdoor fan continue to run and the indoor fan runs at rated speed. After running for 30 minutes, the AC will switch to auto mode with a preset temperature of 24°C.

2. Forced auto mode:

Forced auto mode operates the same as normal auto mode with a preset temperature of 24°C.

3. The unit exits forced operation when it receives the following signals:

- switch on
- switch off
- timer on
- timer off
- changes in:  
mode  
fan speed
- setting temperature.

### 9.4.7 Timer function

1. Timing range is 24 hours.

2.Timer on. The machine will turn on automatically when reaching the setting time.

3.Timer off. The machine will turn off

automatically when reaching the setting time.

4.Timer on/off. The machine will turn on automatically when reaching the setting “on” time, and then turn off automatically when reaching the setting “off” time.

5.Timer off/on. The machine will turn off automatically when reaching the setting “off” time, and then turn on automatically when reaching the setting “on” time.

6.The timer function will not change the AC current operation mode. Suppose AC is off now, it will not start up firstly after setting the “timer off” function. And when reaching the setting time, the timer LED will be off and the AC running mode has not been changed.

7. The setting time is relative time.

8. The AC will quit the timer function when it has malfunction.

### 9.4.8 Sleep function

1 The sleep function is available in cooling, heating, or auto mode.

2. The operational process for sleep mode is as follows:

- When cooling, the temperature rises 1°C (to not higher than 30°C) every hour. After 2 hours, the temperature stops rising and the indoor fan is fixed to low speed.
- When heating, the temperature decreases 1°C (to not lower than 16°C) every hour. After 2 hours, the temperature stops decreasing and the indoor fan is fixed at low speed. Anti-cold wind function takes priority.

3 The operating time for sleep mode is 8 hours, after which, the unit exits this mode and does not switch off.

4 The timer setting is available in this mode.

### 9.4.9 Auto-Restart function



The indoor unit has an auto-restart module that allows the unit to restart automatically. The module automatically stores the current settings and, in the case of a sudden power failure, will restore those setting automatically within 3 minutes after power returns.

If there is a power failure while the unit is running, the compressor starts 3 minutes after the unit restarts. If the unit was already off before the power failure, the unit stands by.

#### **9.4.10 Refrigerant Leakage Detection**

The display area will show “EC” when the outdoor unit detects refrigerant leakage.

#### **9.4.11 8°C Heating**

In heating mode, the temperature can be set to as low as 8°C, preventing the indoor area from freezing if unoccupied during severe cold weather.

#### **9.4.12 ECO function**

1. Used to enter the energy efficient mode.

Under cooling mode, press ECO button, the remote controller will adjust the temperature automatically to 24°C, fan speed of Auto to save energy (but only if the set temperature is less than 24°C). If the set temperature is more than 24 °C and 30°C, press the ECO button, the fan speed will change to Auto, the set temperature will remain unchanged.

2. When AC receives signals, such as switch off, Turbo operation , Silence operation , Self clean operation , Forced cooling operation, mode setting, Sleeping mode, or adjusting the set temperature to less than 24°C, it will quit the ECO operation.

3. Operation time in ECO mode is 8 hours. After 8 hours the AC quits this mode.

4. When there's any one temperature sensor in malfunction, the AC will quit ECO mode .

5. Indoor fan will run at auto fan when enter into the ECO mode .The setting temp. and setting fan speed can be changed through remote controller signal.

#### **9.4.13 Self clean(optional)**

The indoor unit will run at low fan for 16 minutes, then turn off, if you press “Self Clean” when the unit is in cooling or drying mode.

Self Clean keeps the indoor unit dry and prevents mold growth.

#### **9.4.14 Follow me (optional)**

1. If you press “Follow Me” on the remote, the indoor unit will beep. This indicates the follow me function is active.

2. Once active, the remote control will send a signal every 3 minutes, with no beeps. The unit automatically sets the temperature according to the measurements from the remote control.

3. The unit will only change modes if the information from the remote control makes it necessary, not from the unit's temperature setting.

4. If the unit does not receive a signal for 7 minutes or you press “Follow Me,” the function turns off. The unit regulates temperature based on its own sensor and settings

#### **9.4.15 Silence(optional)**

Press “Silence” on the remote control to enable the SILENCE function. While this function is active, the indoor unit will run at faint breeze(1% fan speed), which reduces noise to the lowest possible level.

#### 9.4.16 Electrical energy consumption

##### control function

Press the “Gear” button on remote controller to enter the energy efficient mode in a sequence of following:

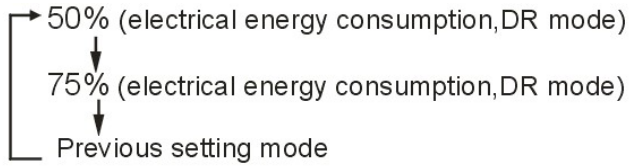

Turn off the unit or activate ECO, sleep, Super cool, Silence or self clean function will quit this function.

### 9.4.19 Information Inquiry

To enter information inquiry status, complete the following procedure within ten seconds:

Press LED 3 times.

Press SWING 3 times.

If you are successful, you will hear beeps for two seconds.

Use the LED and SWING buttons to cycle through information displayed.

Pressing LED will display the next code in the sequence. Pressing SWING will show the previous.

The table shows information codes. The screen will display this code for two seconds, then the information for 25 seconds.

Enquiry information	Displaying code	Meaning
T1	T1	T1 temp.
T2	T2	T2 temp.
T3	T3	T3 temp.
T4	T4	T4 temp.
TP	TP	TP temp.
Targeted frequency	FT	Targeted Frequency
Actual frequency	Tr	Actual Frequency
Compressor current	dL	
Outdoor AC voltage	Uo	
Indoor capacity test	Sn	
Reserve	--	Running mode
Outdoor fan speed	Pr	Outdoor fan speed
EXV opening angle	Lr	EXV opening angle
Indoor fan speed	Ir	Indoor fan speed
Indoor humidity	HU	
Adjusted setting temperature	TT	
Indoor dust concentrations	dT	
WIFI signal strength	IF	
GA algorithm frequency	oT	

# 10. Troubleshooting

## Safety

Electricity power is still kept in capacitors even the power supply is shut off. Do not forget to discharge the electricity power in capacitor.

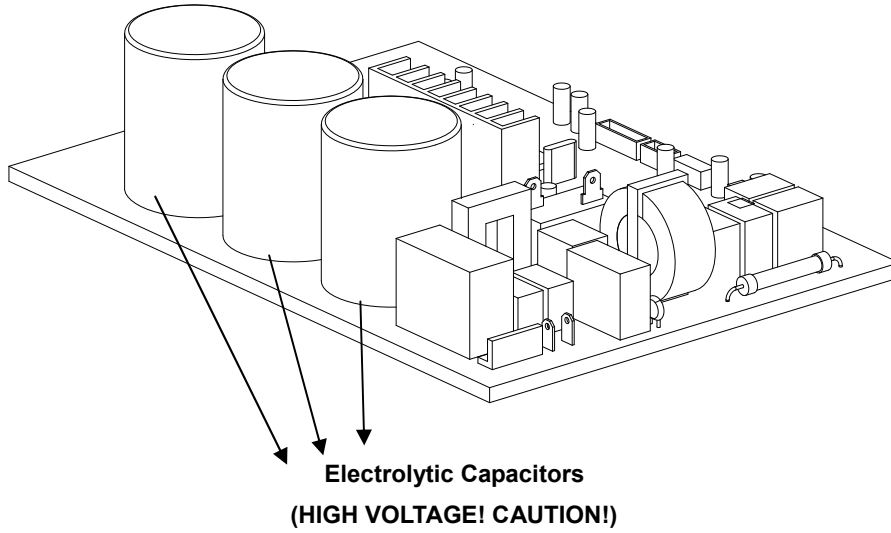

For other models, please connect discharge resistance (approx.100Ω 40W) or soldering iron (plug) between +, - terminals of the electrolytic capacitor on the contrary side of the outdoor PCB.

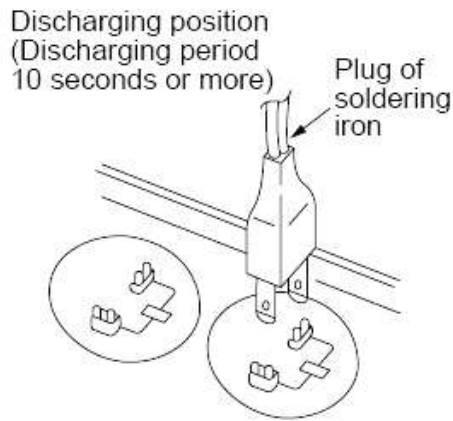

**Note: The picture above is only for reference. The plug of your side may be different.**

## 10.1 Indoor Unit Error Display

Display	LED STATUS
E0/EA	Indoor unit EEPROM parameter error
E1	Indoor / outdoor units communication error
E3	Indoor fan speed is operating outside of the normal range
E4	Indoor room temperature sensor T1 open circuit or short circuit
E5	Evaporator coil temperature sensor T2 open circuit or short circuit
Eb	Communication error between the indoor PCB and display board
F0	Overload current protection
F1	Outdoor ambient temperature sensor T4 open circuit or short circuit
F2	Condenser coil temperature sensor T3 open circuit or short circuit
F3	Compressor discharge temperature sensor T5 open circuit or short circuit
F4	Outdoor unit EEPROM parameter error
F5	Outdoor fan speed is operating outside of the normal range
P0	IPM malfunction or IGBT over-strong current protection
P1	Over or low voltage protection
P2	High temperature protection of IPM module
P4	Inverter compressor drive error

### Trouble shooting:

Use the remote controller. If the unit does not respond to the remote, the indoor PCB needs to be replaced; if the unit does respond, then the display board needs to be replaced.

## 10.2 Trouble shooting

### 10.2.1 EEPROM parameter error diagnosis and solution(E0/F4)

<b>Error Code</b>	<b>E0/F4/EA</b>
<b>Malfunction decision conditions</b>	<b>Indoor or outdoor PCB main chip does not receive feedback from EEPROM chip.</b>
<b>Supposed causes</b>	<ul style="list-style-type: none"><li>● Installation mistake</li><li>● PCB faulty</li></ul>

#### Trouble shooting:

Power off, then restart the unit 2 minutes later.

Yes

Replace the indoor/outdoor main PCB.

EEPROM: a read-only memory whose contents can be erased and reprogrammed using a pulsed voltage. For the location of EEPROM chip, please refer to the below photos.

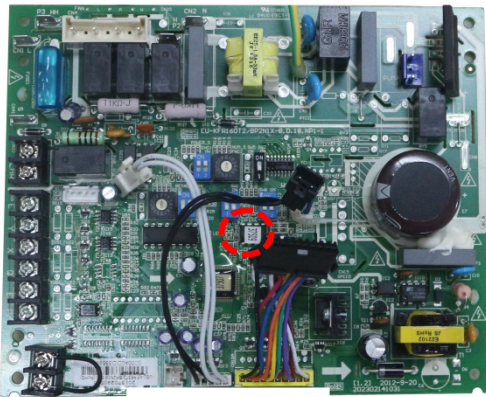

Indoor PCB

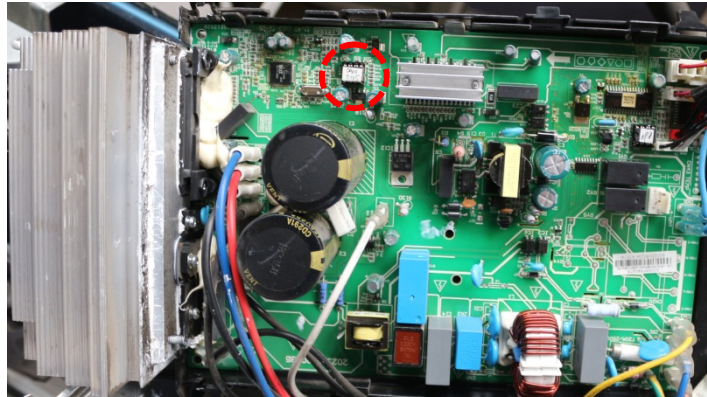

Outdoor PCB

**Note:** The two photos above are only for reference, it's may be not same totally with the ones on your side.

### 10.2.2 Indoor / outdoor unit's communication diagnosis and solution(E1)

<b>Error Code</b>	<b>E1</b>
<b>Malfunction decision conditions</b>	<b>Indoor unit does not receive the feedback from outdoor unit during 150 seconds and this condition happens four times continuously.</b>
<b>Supposed causes</b>	<ul style="list-style-type: none"> <li>● <b>Wiring mistake</b></li> <li>● <b>Indoor or outdoor PCB faulty</b></li> </ul>

**Trouble shooting:**

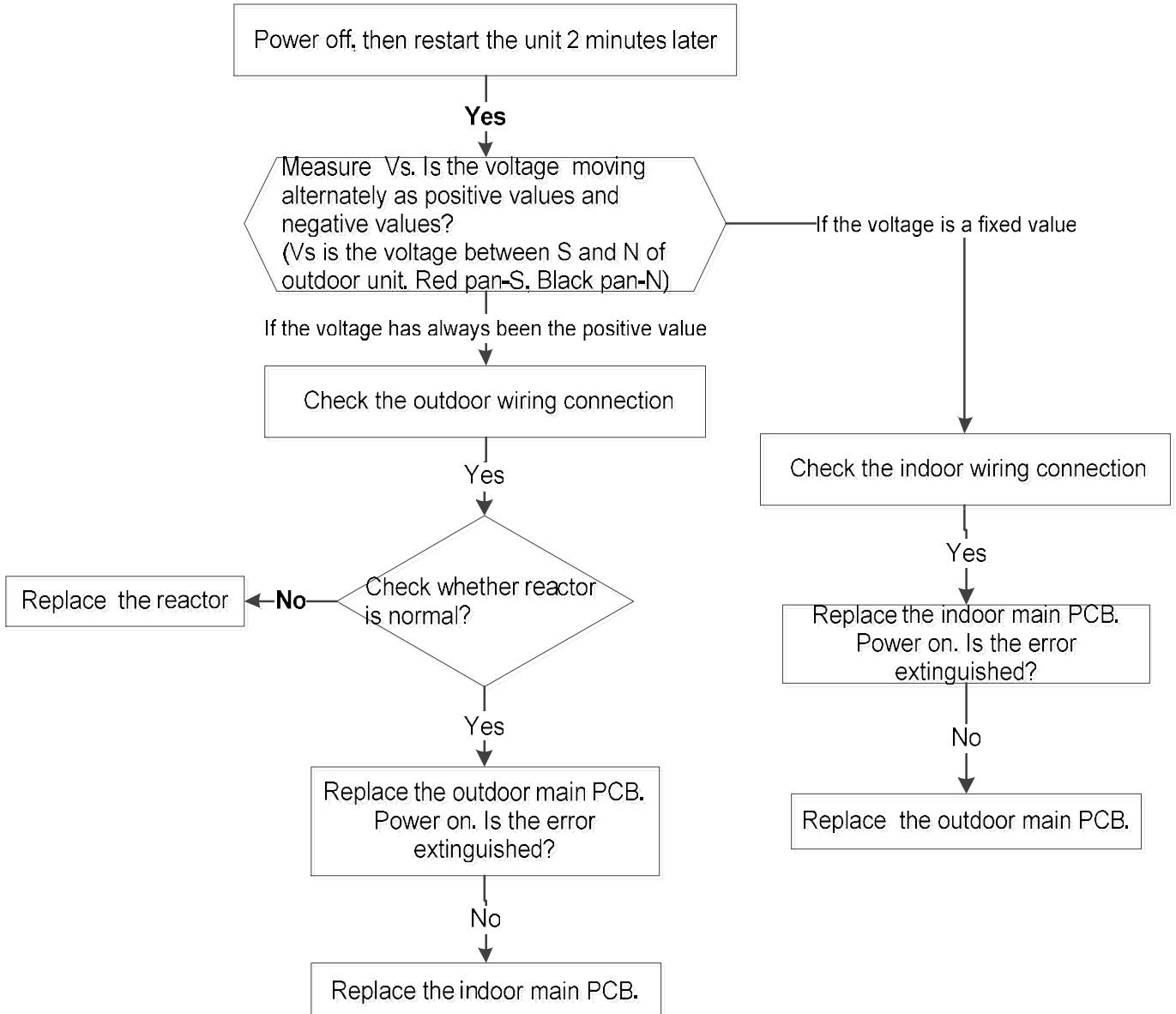

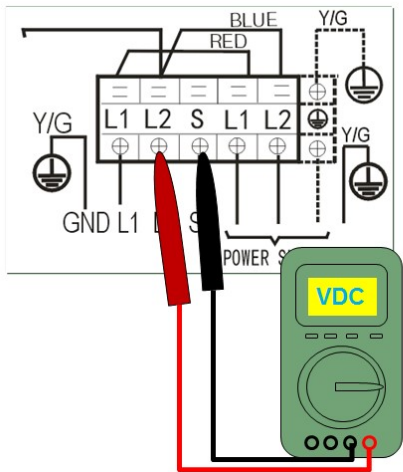

*S and N  
or  
L2 and S  
Or  
2 and 3*

**Remark:**  
Use a multimeter to test the DC voltage between 2 port and 3 port of outdoor unit. The red pin of multimeter connects with 2 port while the black pin is for 3 port.

When AC is normal running, the voltage is moving alternately as positive values and negative values

If the outdoor unit has malfunction, the voltage has always been the positive value

While if the indoor unit has malfunction, the voltage is a fixed value.



**Remark:**  
Use a multimeter to test the resistance of the reactor which does not connect with capacitor. The normal value should be around zero ohm. Otherwise, the reactor must have malfunction.



**10.2.3 Fan speed is operating outside of the normal range diagnosis and solution(E3/F5)**

<b>Error Code</b>	<b>E3/F5</b>
<b>Malfunction decision conditions</b>	<b>When the indoor fan speed registers below 200RPM or over 2100RPM for an extended period of time, the unit will stop and the LED will display the failure.</b>
<b>Supposed causes</b>	<ul style="list-style-type: none"> <li>● <b>Wiring mistake</b></li> <li>● <b>Fan ass'y faulty</b></li> <li>● <b>Fan motor faulty</b></li> <li>● <b>PCB faulty</b></li> </ul>

**Trouble shooting:**

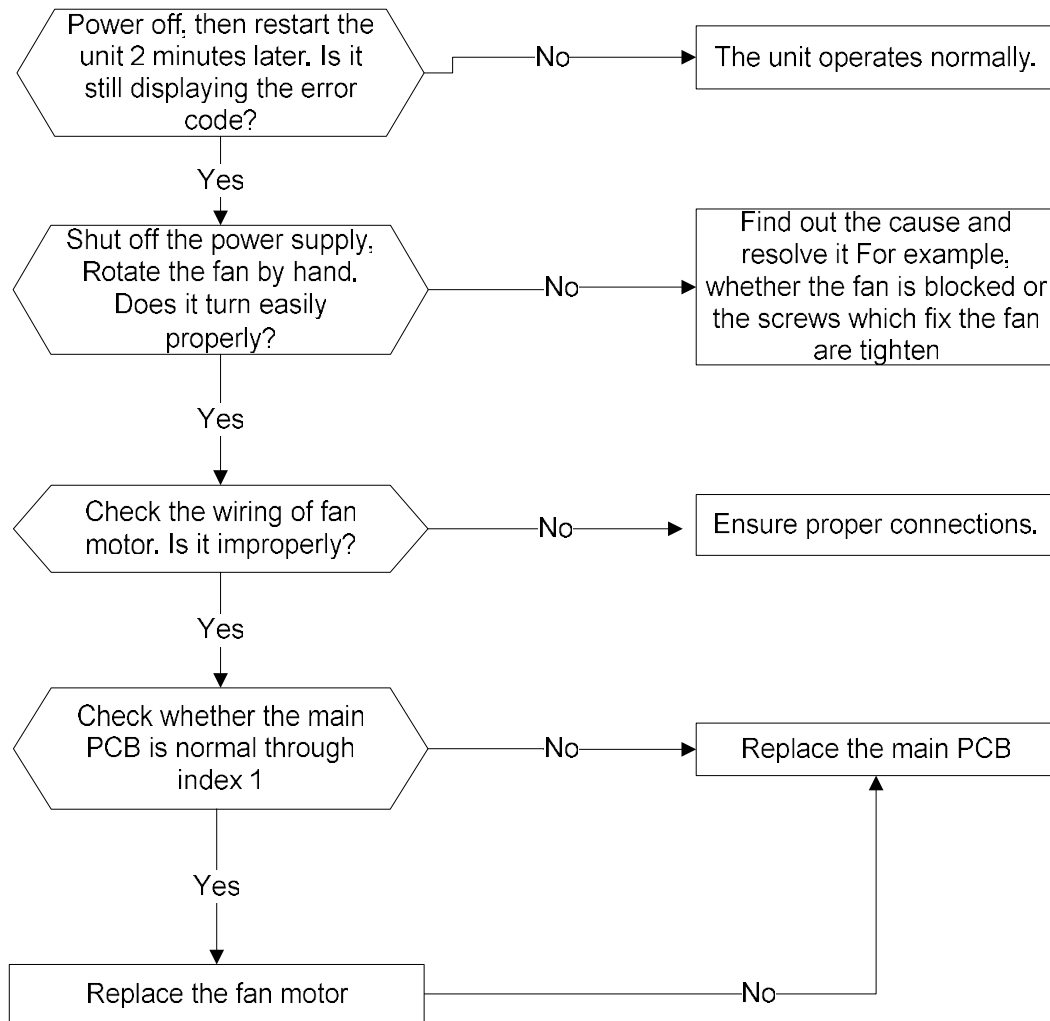

Index1:

1:Indoor DC Fan Motor(control chip is in fan motor)

Power on and when the unit is in standby, measure the voltage of pin1-pin3, pin4-pin3 in fan motor connector. If the value of the voltage is not in the range showing in below table, the PCB must has problems and need to be replaced.

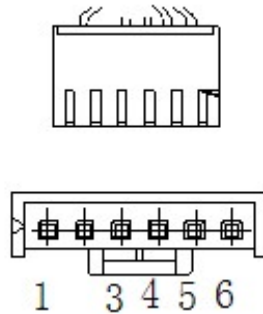

DC motor voltage input and output

NO.	Color	Signal	Voltage
1	Red	Vs/Vm	280V~380V
2	---	---	---
3	Black	GND	0V
4	White	Vcc	14-18.5V
5	Yellow	Vsp	0~5.6V
6	Blue	FG	14-18.5V

2. Outdoor DC Fan Motor (control chip is in outdoor PCB)

Power on ,and check if the fan can run normally, if the fan can run normally, the PCB must has problems and need to be replaced, If the fan can't run normally, measure the resistance of each two pins. If the resistance is not equal to each other, the fan motor must have problems and need to be replaced, otherwise the PCB must has problems and need to be replaced.

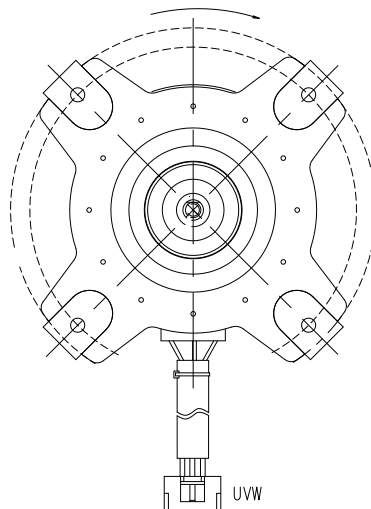

**10.2.4 Open circuit or short circuit of temperature sensor diagnosis and solution (E4/E5/F1/F2/F3)**

<b>Error Code</b>	<b>E4/E5/F1/F2/F3</b>
<b>Malfunction decision conditions</b>	If the sampling voltage is lower than 0.06V or higher than 4.94V, the LED will display the failure.
<b>Supposed causes</b>	<ul style="list-style-type: none"> <li>● Wiring mistake</li> <li>● Sensor faulty</li> </ul>

**Trouble shooting:**

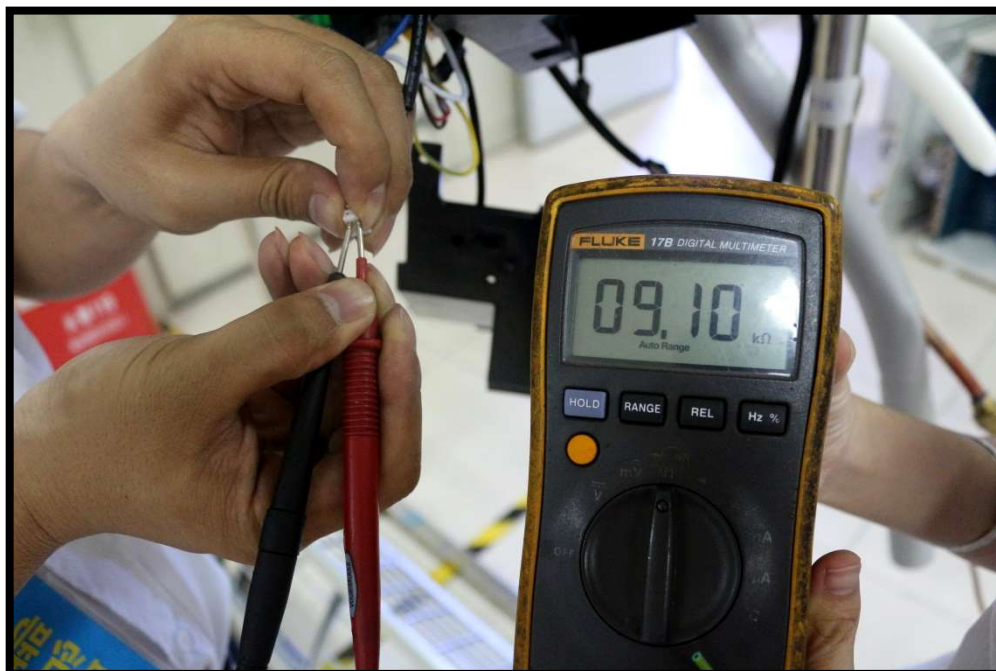
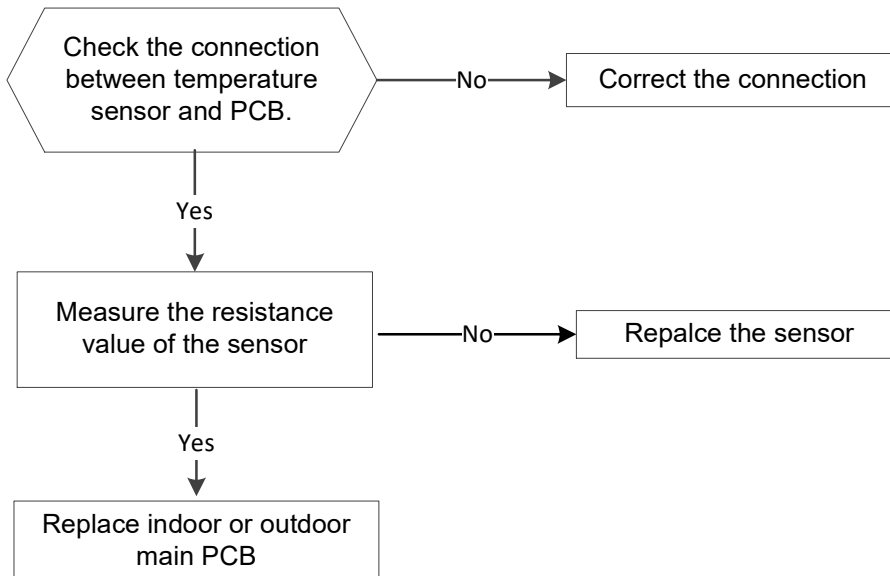

### 10.2.5 Communication error between the indoor PCB and display board (Eb)

<b>Error Code</b>	<b>Eb</b>
<b>Malfunction decision conditions</b>	<b>Indoor PCB does not receive feedback from Display board.</b>
<b>Supposed causes</b>	<ul style="list-style-type: none"> <li>● <b>Wiring mistake</b></li> <li>● <b>PCB faulty</b></li> <li>● <b>Display board malfunction</b></li> </ul>

**Trouble shooting:**

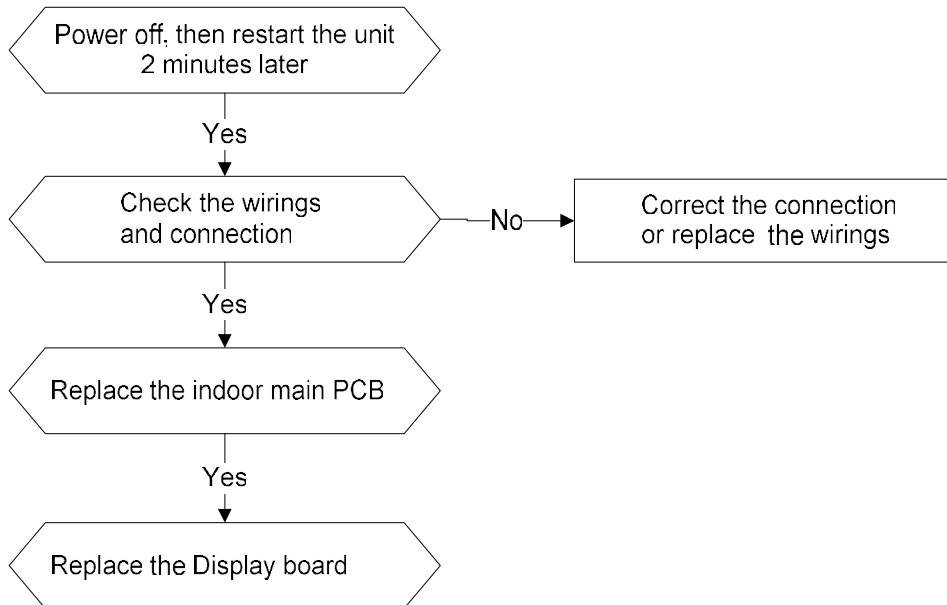

### 10.2.6 Overload current protection diagnosis and solution(F0)

<b>Error Code</b>	<b>F0</b>
<b>Malfunction decision conditions</b>	<b>An abnormal current rise is detected by checking the specified current detection circuit.</b>
<b>Supposed causes</b>	<ul style="list-style-type: none"> <li>● <b>Power supply problems.</b></li> <li>● <b>System blockage</b></li> <li>● <b>PCB faulty</b></li> <li>● <b>Wiring mistake</b></li> <li>● <b>Compressor malfunction</b></li> </ul>

**Trouble shooting:**

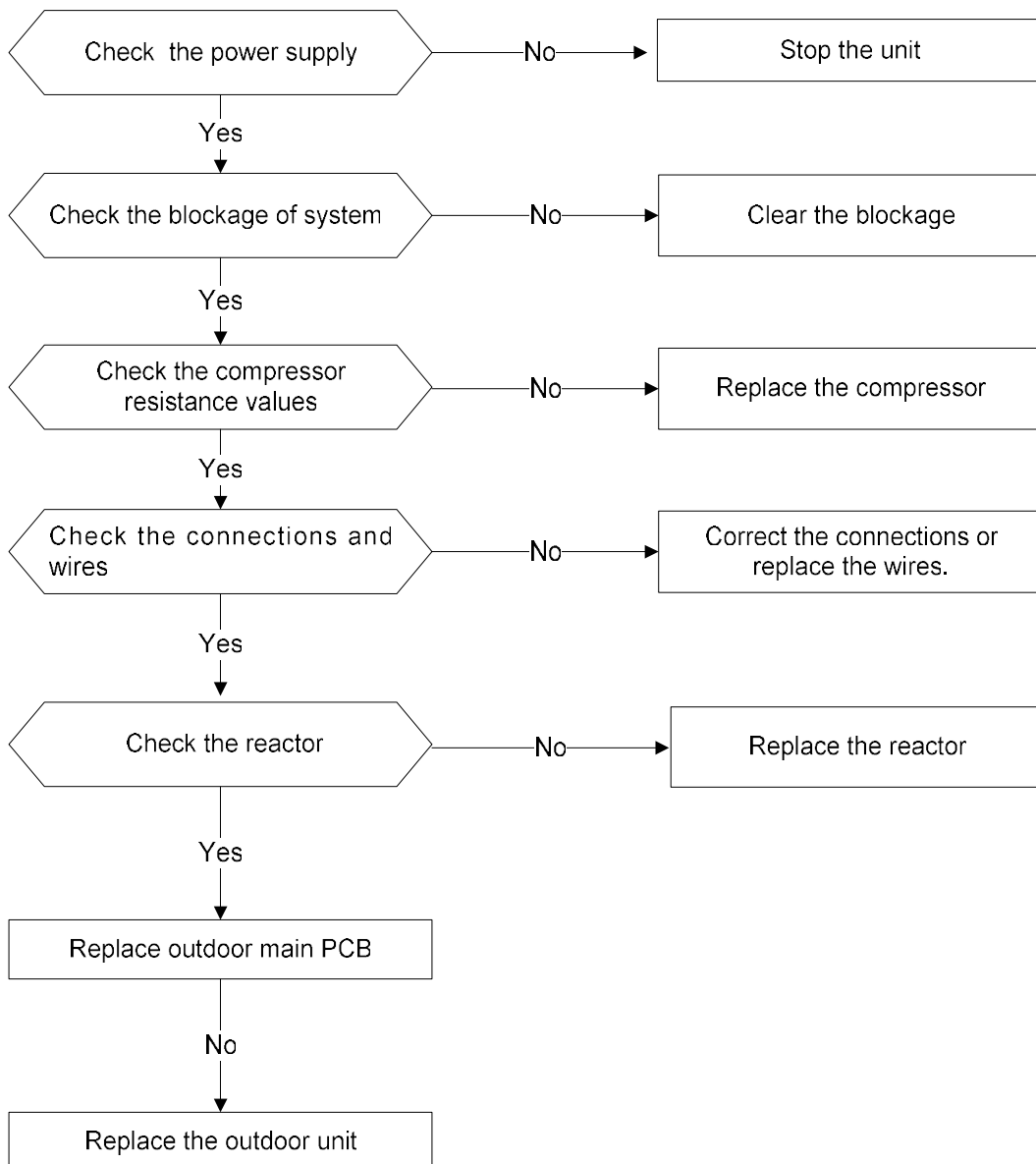

### 10.2.7 IPM malfunction or IGBT over-strong current protection diagnosis and solution(P0)

<b>Error Code</b>	<b>P0</b>
<b>Malfunction decision conditions</b>	When the voltage signal that IPM send to compressor drive chip is abnormal, the display LED will show “P0” and AC will turn off.
<b>Supposed causes</b>	<ul style="list-style-type: none"> <li>● Wiring mistake</li> <li>● IPM malfunction</li> <li>● Outdoor fan ass’y faulty</li> <li>● Compressor malfunction</li> <li>● Outdoor PCB faulty</li> </ul>

**Trouble shooting:**

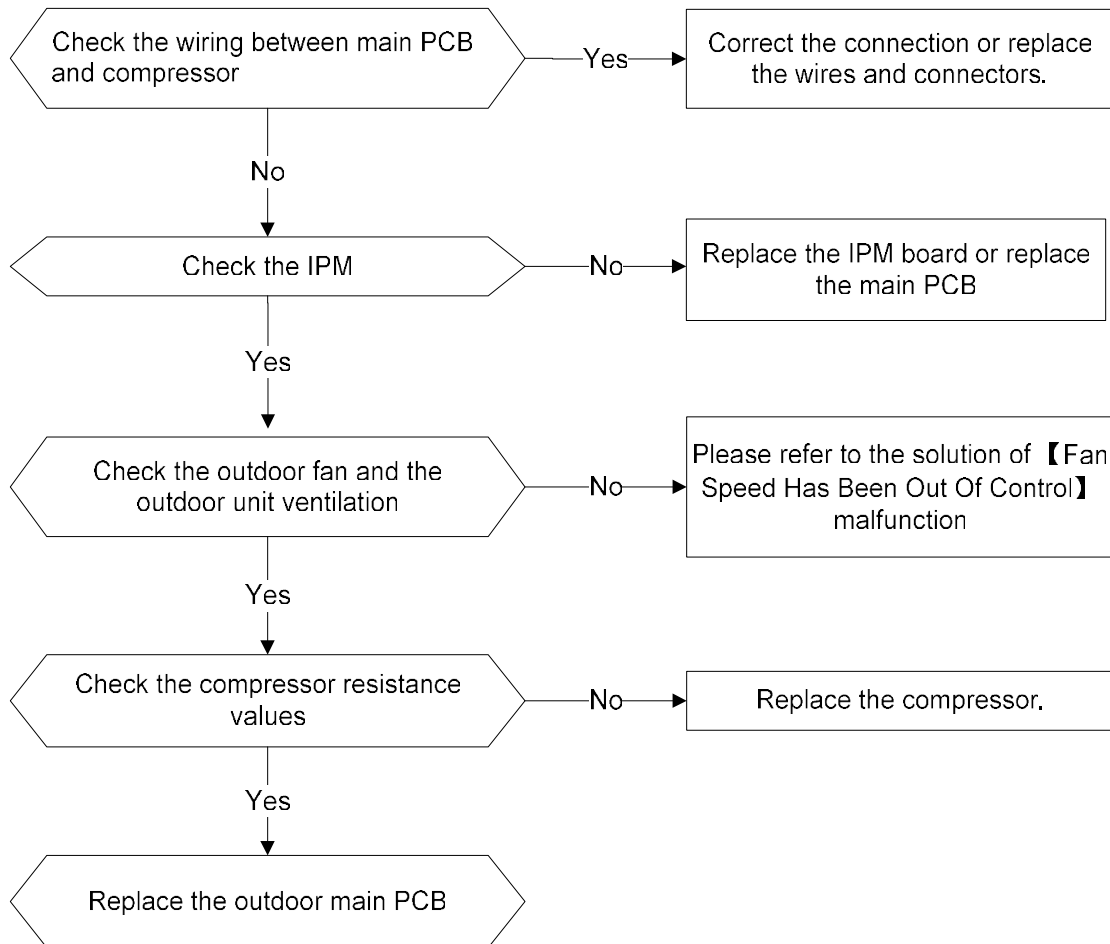

➤ **IPM continuity check**

Turn off the power, let the large capacity electrolytic capacitors discharge completely, and dismount the IPM. Use a digital tester to measure the resistance between P and UVWN; UVW and N.

Digital tester		Normal resistance value	Digital tester		Normal resistance value
(+)Red	(-)Black		(+)Red	(-)Black	
P	N	∞ (Several MΩ)	U	N	∞ (Several MΩ)
	U				
	V				
	W				
			(+)Red		

### 10.2.8 Over voltage or too low voltage protection diagnosis and solution(P1)

<b>Error Code</b>	<b>P1</b>
<b>Malfunction decision conditions</b>	<b>An abnormal voltage rise or drop is detected by checking the specified voltage detection circuit.</b>
<b>Supposed causes</b>	<ul style="list-style-type: none"> <li>● <b>Power supply problems.</b></li> <li>● <b>System leakage or block</b></li> <li>● <b>PCB faulty</b></li> </ul>

**Trouble shooting:**

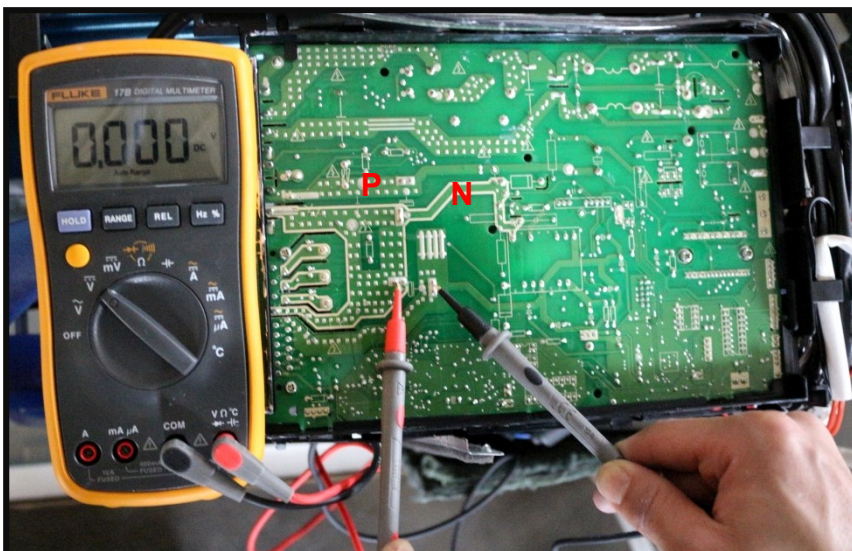
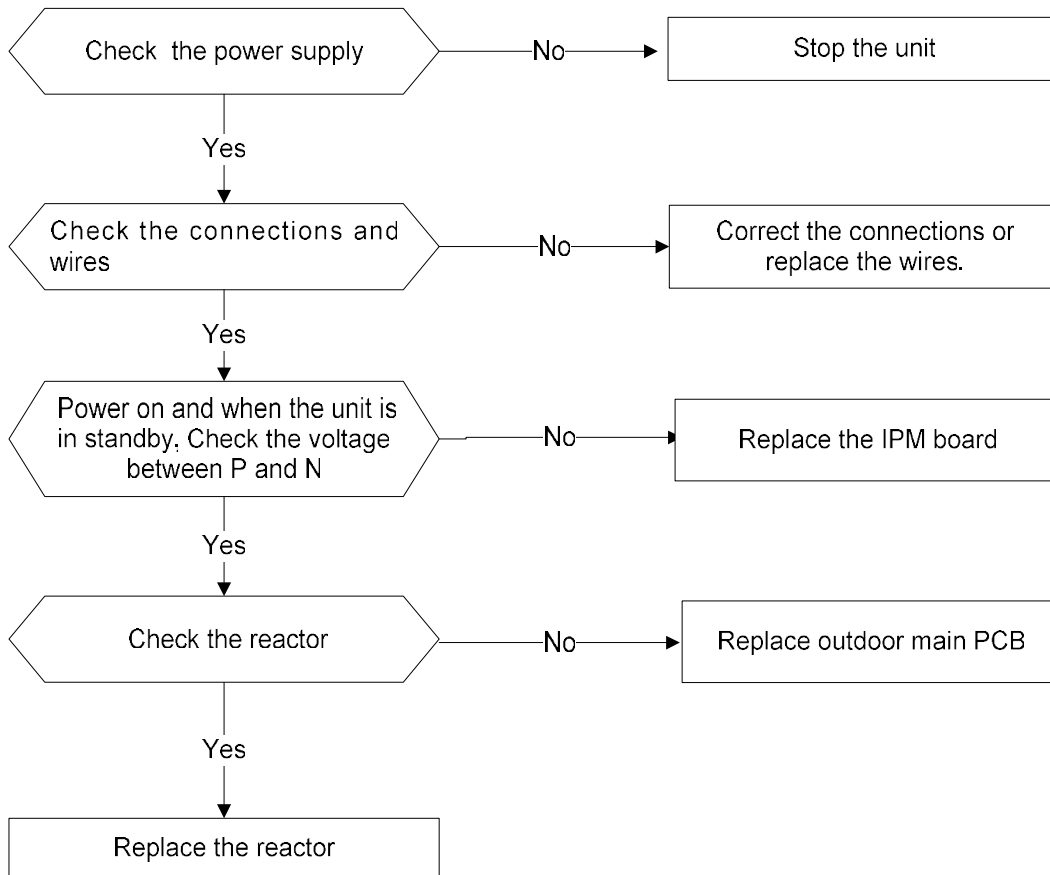

### 10.2.9 High temperature protection of IPM diagnosis and solution (P2)

<b>Error Code</b>	<b>P2</b>
<b>Malfunction decision conditions</b>	<b>If the temperature of IPM module is higher than limited value, the LED will display the failure.</b>
<b>Supposed causes</b>	<ul style="list-style-type: none"><li>● IPM radiator problem</li><li>● PCB faulty</li></ul>

#### Trouble shooting:

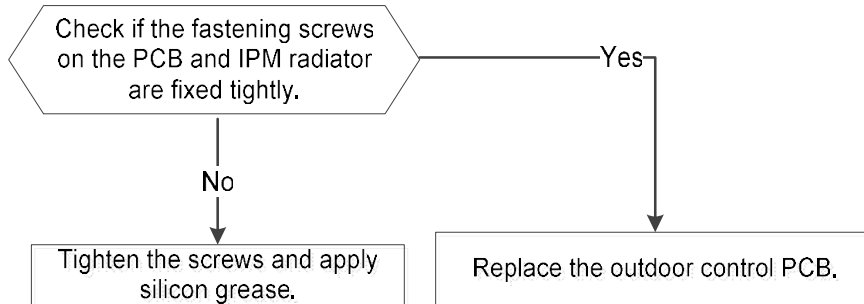



### 10.2.10 Inverter compressor drive error diagnosis and solution(P4)

<b>Error Code</b>	<b>P4</b>
<b>Malfunction decision conditions</b>	<b>An abnormal inverter compressor drive is detected by a special detection circuit, including communication signal detection, voltage detection, compressor rotation speed signal detection and so on.</b>
<b>Supposed causes</b>	<ul style="list-style-type: none"> <li>● <b>Wiring mistake</b></li> <li>● <b>IPM malfunction</b></li> <li>● <b>Outdoor fan ass'y faulty</b></li> <li>● <b>Compressor malfunction</b></li> <li>● <b>Outdoor PCB faulty</b></li> </ul>

**Trouble shooting:**

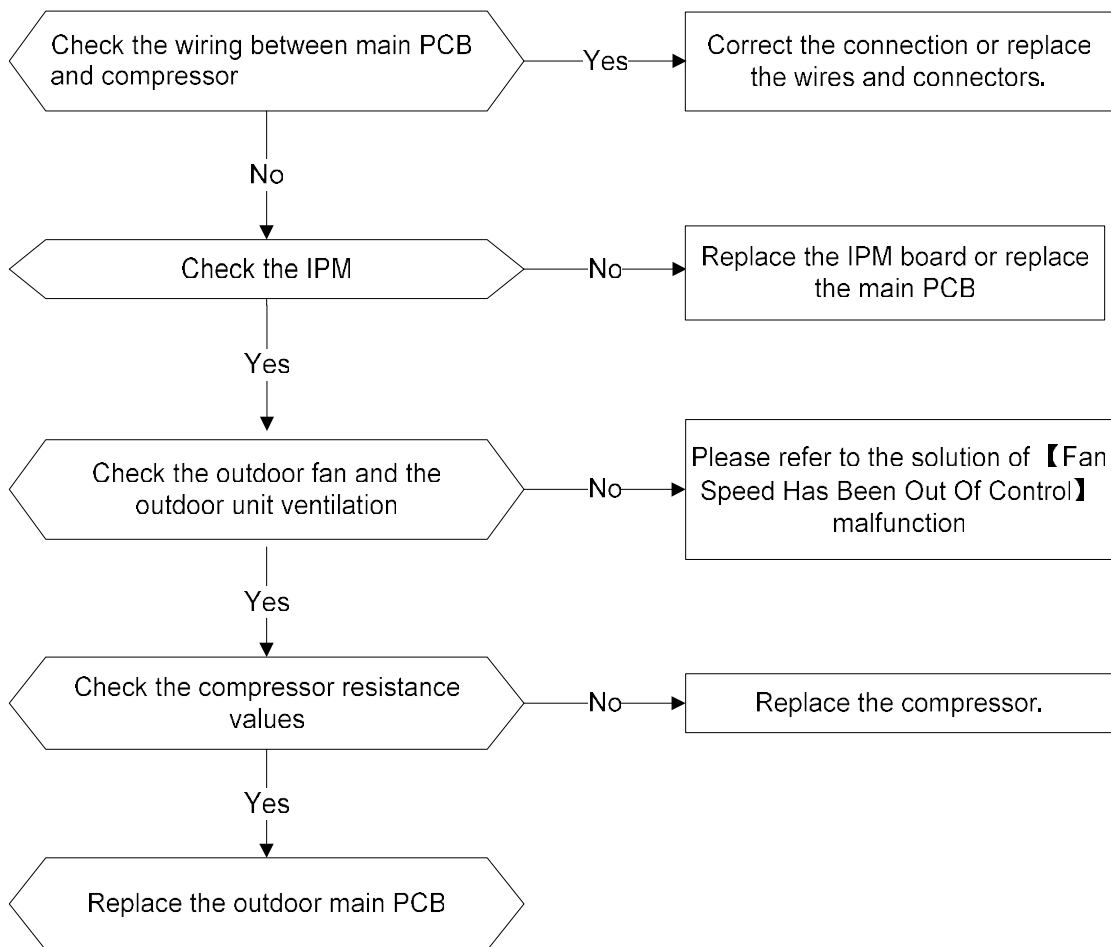

## Main parts check

### 1. Temperature sensor checking

Disconnect the temperature sensor from PCB, measure the resistance value with a tester.

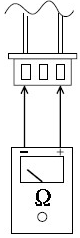

Tester

Temperature Sensors.

Room temp.(T1) sensor,

Indoor coil temp.(T2) sensor,

Outdoor coil temp.(T3) sensor,

Outdoor ambient temp.(T4) sensor,

Compressor discharge temp.(T5) sensor.

Measure the resistance value of each winding by using the multi-meter.

**Appendix 1** Temperature Sensor Resistance Value Table for T1,T2,T3,T4 (°C--K)

°C	°F	K Ohm	°C	°F	K Ohm	°C	°F	K Ohm	°C	°F	K Ohm
-20	-4	115.266	20	68	12.6431	60	140	2.35774	100	212	0.62973
-19	-2	109.146	21	70	12.0561	61	142	2.27249	101	214	0.61148
-18	0	101.517	22	72	11.5	62	144	2.19073	102	216	0.59386
-17	1	96.3423	23	73	10.9731	63	145	2.11241	103	217	0.57683
-16	3	89.5865	24	75	10.4736	64	147	2.03732	104	219	0.56038
-15	5	84.219	25	77	10	65	149	1.96532	105	221	0.54448
-14	7	79.311	26	79	9.55074	66	151	1.89627	106	223	0.52912
-13	9	74.536	27	81	9.12445	67	153	1.83003	107	225	0.51426
-12	10	70.1698	28	82	9.71983	68	154	1.76647	108	226	0.49989
-11	12	66.0898	29	84	9.33566	69	156	1.70547	109	228	0.486
-10	14	62.2756	30	86	8.97078	70	158	1.64691	110	230	0.47256
-9	16	59.7079	31	88	8.62411	71	160	1.59068	111	232	0.45957
-8	18	56.3694	32	90	8.29464	72	162	1.53668	112	234	0.44699
-7	19	52.2438	33	91	6.98142	73	163	1.48481	113	235	0.43482
-6	21	49.3161	34	93	6.68355	74	165	1.43498	114	237	0.42304
-5	23	46.5725	35	95	6.40021	75	167	1.38703	115	239	0.41164
-4	25	44	36	97	6.13059	76	169	1.34105	116	241	0.4006
-3	27	41.5878	37	99	5.87359	77	171	1.29078	117	243	0.38991
-2	28	39.8239	38	100	5.62961	78	172	1.25423	118	244	0.37956
-1	30	38.1988	39	102	5.39689	79	174	1.2133	119	246	0.36954
0	32	35.2024	40	104	5.17519	80	176	1.17393	120	248	0.35982
1	34	33.3269	41	106	4.96392	81	178	1.13604	121	250	0.35042
2	36	31.5635	42	108	4.76253	82	180	1.09958	122	252	0.3413
3	37	29.9058	43	109	4.5705	83	181	1.06448	123	253	0.33246
4	39	29.3459	44	111	4.38736	84	183	1.03069	124	255	0.3239
5	41	26.8778	45	113	4.21263	85	185	0.99815	125	257	0.31559
6	43	25.4954	46	115	4.04589	86	187	0.96681	126	259	0.30754
7	45	24.1932	47	117	3.88673	87	189	0.93662	127	261	0.29974
8	46	22.5662	48	118	3.73476	88	190	0.90753	128	262	0.29216
9	48	21.8094	49	120	3.58962	89	192	0.8795	129	264	0.28482
10	50	20.7184	50	122	3.45097	90	194	0.85248	130	266	0.2777
11	52	19.6891	51	124	3.31847	91	196	0.82643	131	268	0.27078
12	54	19.7177	52	126	3.19183	92	198	0.80132	132	270	0.26408
13	55	18.8005	53	127	3.07075	93	199	0.77709	133	271	0.25757
14	57	16.9341	54	129	2.95896	94	201	0.75373	134	273	0.25125
15	59	16.1156	55	131	2.84421	95	203	0.73119	135	275	0.24512
16	61	15.3418	56	133	2.73823	96	205	0.70944	136	277	0.23916
17	63	14.6181	57	135	2.63682	97	207	0.68844	137	279	0.23338
18	64	13.918	58	136	2.53973	98	208	0.66818	138	280	0.22776
19	66	13.2631	59	138	2.44677	99	210	0.64862	139	282	0.22231

**Appendix 2** Temperature Sensor Resistance Value Table for T5 (°C --K)

°C	°F	K Ohm	°C	°F	K Ohm	°C	°F	K Ohm	°C	°F	K Ohm
-20	-4	542.7	20	68	69.66	60	140	13.59	100	212	3.702
-19	-2	511.9	21	70	65.62	61	142	13.11	101	214	3.595
-18	0	483	22	72	62.73	62	144	12.65	102	216	3.492
-17	1	455.9	23	73	59.98	63	145	12.21	103	217	3.392
-16	3	430.5	24	75	58.37	64	147	11.79	104	219	3.296
-15	5	406.7	25	77	54.89	65	149	11.38	105	221	3.203
-14	7	384.3	26	79	52.53	66	151	10.99	106	223	3.113
-13	9	363.3	27	81	50.28	67	153	10.61	107	225	3.025
-12	10	343.6	28	82	49.14	68	154	10.25	108	226	2.941
-11	12	325.1	29	84	46.11	69	156	9.902	109	228	2.86
-10	14	308.7	30	86	44.17	70	158	9.569	110	230	2.781
-9	16	291.3	31	88	42.33	71	160	9.248	111	232	2.704
-8	18	275.9	32	90	40.57	72	162	9.94	112	234	2.63
-7	19	261.4	33	91	39.89	73	163	9.643	113	235	2.559
-6	21	248.8	34	93	38.3	74	165	9.358	114	237	2.489
-5	23	234.9	35	95	35.78	75	167	9.084	115	239	2.422
-4	25	222.8	36	97	34.32	76	169	8.82	116	241	2.357
-3	27	211.4	37	99	32.94	77	171	8.566	117	243	2.294
-2	28	200.7	38	100	31.62	78	172	8.321	118	244	2.233
-1	30	190.5	39	102	30.36	79	174	8.086	119	246	2.174
0	32	180.9	40	104	29.15	80	176	6.859	120	248	2.117
1	34	171.9	41	106	28	81	178	6.641	121	250	2.061
2	36	163.3	42	108	26.9	82	180	6.43	122	252	2.007
3	37	155.2	43	109	25.86	83	181	6.228	123	253	1.955
4	39	148.6	44	111	24.85	84	183	6.033	124	255	1.905
5	41	140.4	45	113	23.89	85	185	5.844	125	257	1.856
6	43	133.5	46	115	22.89	86	187	5.663	126	259	1.808
7	45	128.1	47	117	22.1	87	189	5.488	127	261	1.762
8	46	121	48	118	21.26	88	190	5.32	128	262	1.717
9	48	115.2	49	120	20.46	89	192	5.157	129	264	1.674
10	50	109.8	50	122	19.69	90	194	5	130	266	1.632
11	52	104.6	51	124	19.96	91	196	4.849			
12	54	99.69	52	126	19.26	92	198	4.703			
13	55	95.05	53	127	18.58	93	199	4.562			
14	57	90.66	54	129	16.94	94	201	4.426			
15	59	86.49	55	131	16.32	95	203	4.294			
16	61	82.54	56	133	15.73	96	205	4.167			
17	63	79.79	57	135	15.16	97	207	4.045			
18	64	75.24	58	136	14.62	98	208	3.927			
19	66	71.86	59	138	14.09	99	210	3.812			

## 2.Compressor checking

Measure the resistance value of each winding by using the tester.

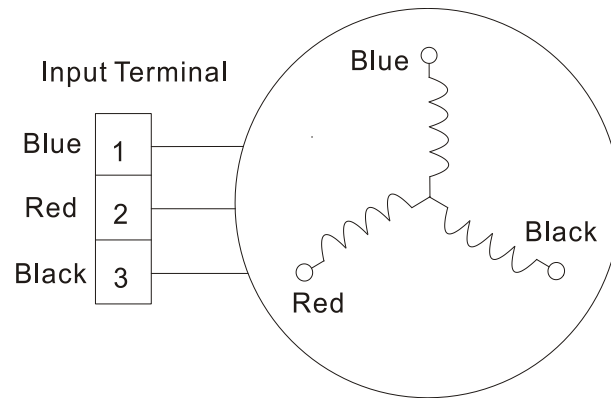

Position	Resistance Value		
	KSN98D22UFZ	KSM135D23UFZ	KTF235D22UMT
Blue - Red	1.57Ω (20°C/68°F)	1.72Ω (20°C/68°F)	0.75Ω (20°C/68°F)
Blue - Black			
Red - Blue			